

Test Bank for Thomas Calculus Early Transcendentals 14th Edition by Hass

[CLICK HERE TO ACCESS COMPLETE Test Bank](#)

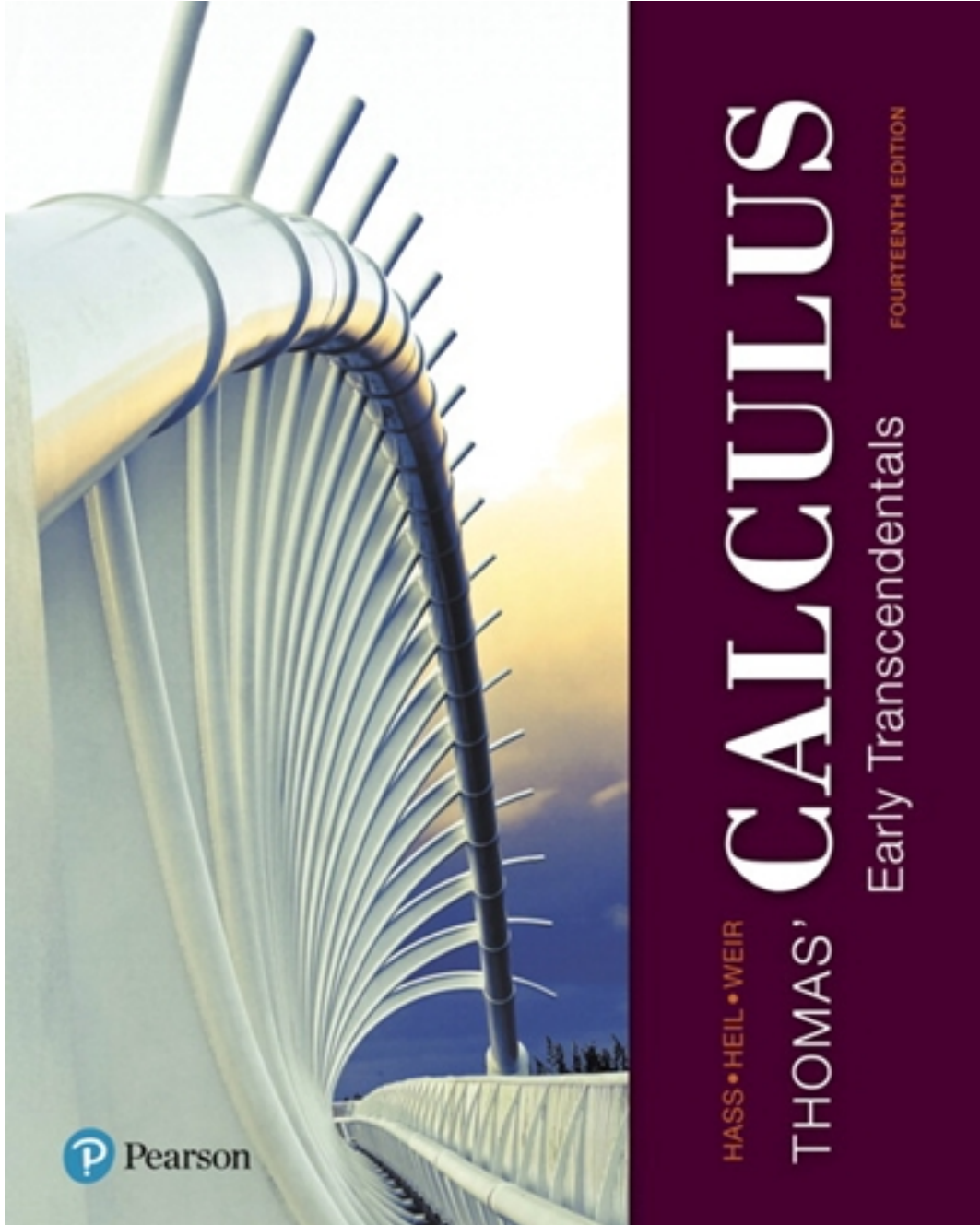

Test Bank

MULTIPLE CHOICE. Choose the one alternative that best completes the statement or answers the question.

Find the average rate of change of the function over the given interval.

1) $y = x^2 + 9x$, $[1, 8]$

A) 17

B) $\frac{63}{4}$

C) $\frac{136}{7}$

D) 18

Answer: D

2) $y = 5x^3 - 8x^2 - 3$, $[-9, 5]$

A) 337

B) $\frac{4718}{5}$

C) $\frac{211}{7}$

D) $\frac{422}{5}$

Answer: A

3) $y = \sqrt{2x}$, $[2, 8]$

A) 7

B) $\frac{1}{3}$

C) 2

D) $-\frac{3}{10}$

Answer: B

4) $y = \frac{3}{x-2}$, $[4, 7]$

A) 7

B) 2

C) $-\frac{3}{10}$

D) $\frac{1}{3}$

Answer: C

5) $y = 4x^2$, $\left[0, \frac{7}{4}\right]$

A) $-\frac{3}{10}$

B) 2

C) 7

D) $\frac{1}{3}$

Answer: C

6) $y = -3x^2 - x$, $[5, 6]$

A) $\frac{1}{2}$

B) $-\frac{1}{6}$

C) -2

D) -34

Answer: D

7) $h(t) = \sin(5t)$, $\left[0, \frac{\pi}{10}\right]$

A) $\frac{10}{\pi}$

B) $\frac{5}{\pi}$

C) $-\frac{10}{\pi}$

D) $\frac{\pi}{10}$

Answer: A

8) $g(t) = 4 + \tan t$, $\left[-\frac{\pi}{4}, \frac{\pi}{4}\right]$

A) $-\frac{3}{2}$

B) 0

C) $-\frac{4}{\pi}$

D) $\frac{4}{\pi}$

Answer: D

Find the slope of the curve at the given point P and an equation of the tangent line at P.

9) $y = x^2 + 5x$, P(4, 36)

A) slope is $\frac{1}{20}$; $y = \frac{x}{20} + \frac{1}{5}$

B) slope is -39; $y = -39x - 80$

C) slope is $-\frac{4}{25}$; $y = -\frac{4x}{25} + \frac{8}{5}$

D) slope is 13; $y = 13x - 16$

Answer: D

10) $y = x^2 + 11x - 15$, P(1, -3)

A) slope is $-\frac{4}{25}$; $y = -\frac{4x}{25} + \frac{8}{5}$

B) slope is -39; $y = -39x - 80$

C) slope is 13; $y = 13x - 16$

D) slope is $\frac{1}{20}$; $y = \frac{x}{20} + \frac{1}{5}$

Answer: C

11) $y = x^3 - 8x$, P(1, -7)

A) slope is -5; $y = -5x - 2$

B) slope is -5; $y = -5x$

C) slope is 3; $y = 3x - 10$

D) slope is 3; $y = 3x - 6$

Answer: A

12) $y = x^3 - 2x^2 + 4$, P(1, 3)

A) slope is -1; $y = -1x + 3$

B) slope is 0; $y = 4$

C) slope is -1; $y = -1x + 4$

D) slope is 1; $y = x + 4$

Answer: C

13) $y = 4 - x^3$, (1, 3)

A) slope is -1; $y = -x + 6$

B) slope is 0; $y = 6$

C) slope is -3; $y = -3x + 6$

D) slope is 3; $y = 3x + 6$

Answer: C

Use the slopes of UQ, UR, US, and UT to estimate the rate of change of y at the specified value of x.

14) $x = 5$

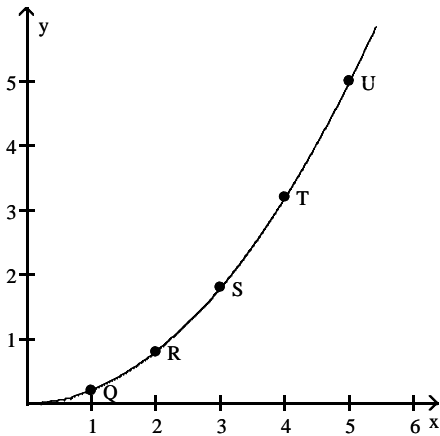

A) 0

B) 5

C) 1

D) 2

Answer: D

15) $x = 3$

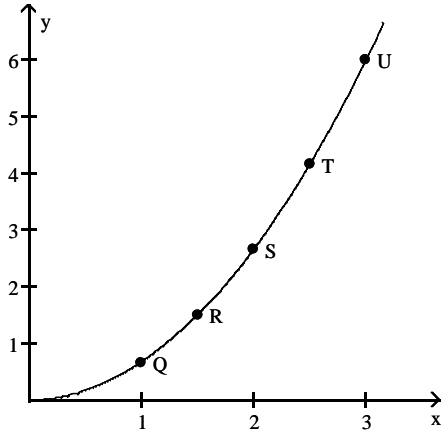

A) 2

B) 6

C) 0

D) 4

Answer: D

16) $x = 5$

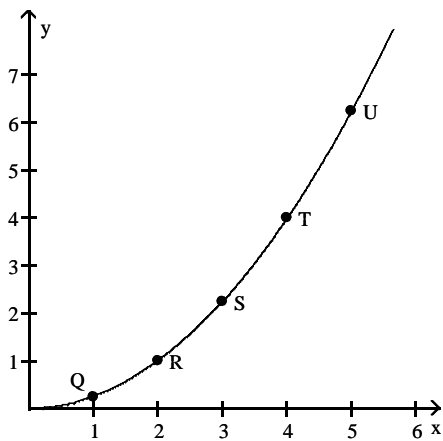

A) $\frac{5}{4}$

B) $\frac{5}{2}$

C) $\frac{25}{4}$

D) 0

Answer: B

17) $x = 2$

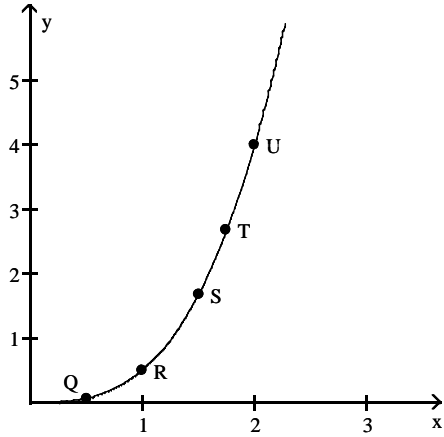

A) 3

B) 0

C) 6

D) 4

Answer: C

18) $x = 2.5$

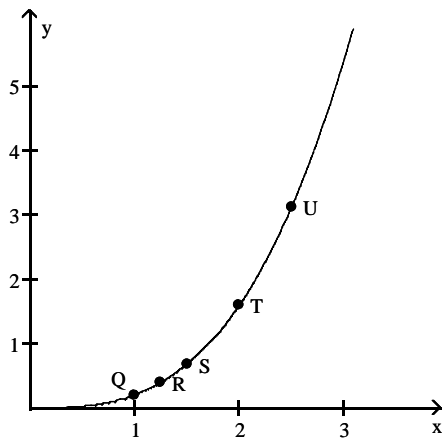

A) 3.75

B) 1.25

C) 0

D) 7.5

Answer: A

Use the table to estimate the rate of change of y at the specified value of x .

19) $x = 1$.

x	y
0	0
0.2	0.02
0.4	0.08
0.6	0.18
0.8	0.32
1.0	0.5
1.2	0.72
1.4	0.98

A) 0.5

B) 2

C) 1.5

D) 1

Answer: D

20) $x = 1$.

x	y
0	0
0.2	0.01
0.4	0.04
0.6	0.09
0.8	0.16
1.0	0.25
1.2	0.36
1.4	0.49

A) 2

B) 0.5

C) 1

D) 1.5

Answer: B

21) $x = 1$.

x	y
0	0
0.2	0.12
0.4	0.48
0.6	1.08
0.8	1.92
1.0	3
1.2	4.32
1.4	5.88

A) 2

B) 4

C) 6

D) 8

Answer: C

22) $x = 2$.

x	y
0	10
0.5	38
1.0	58
1.5	70
2.0	74
2.5	70
3.0	58
3.5	38
4.0	10

A) 4

B) -8

C) 8

D) 0

Answer: D

23) $x = 1$.

x	y
0.900	-0.05263
0.990	-0.00503
0.999	-0.0005
1.000	0.0000
1.001	0.0005
1.010	0.00498
1.100	0.04762

A) -0.5

B) 1

C) 0

D) 0.5

Answer: D

Solve the problem.

- 24) When exposed to ethylene gas, green bananas will ripen at an accelerated rate. The number of days for ripening becomes shorter for longer exposure times. Assume that the table below gives average ripening times of bananas several different ethylene exposure times:

Exposure time (minutes)	Ripening Time (days)
10	4.2
15	3.5
20	2.6
25	2.1
30	1.1

Plot the data and then find a line approximating the data. With the aid of this line, find the limit of the average ripening time as the exposure time to ethylene approaches 0. Round your answer to the nearest tenth.

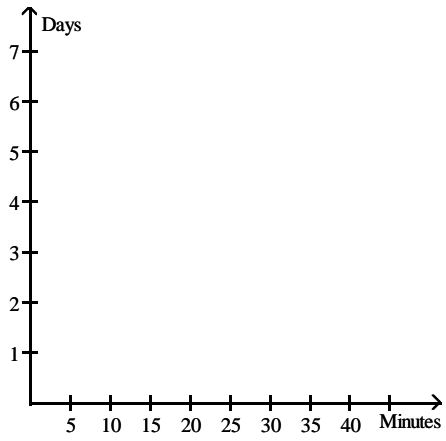

A)

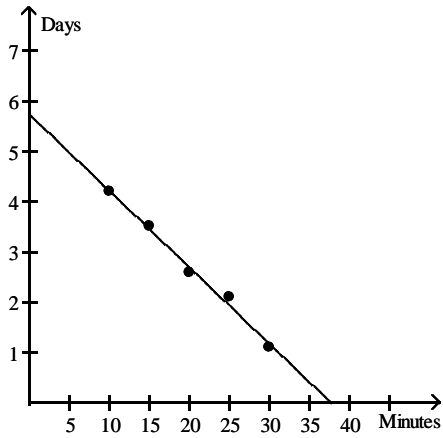

37.5 minutes

B)

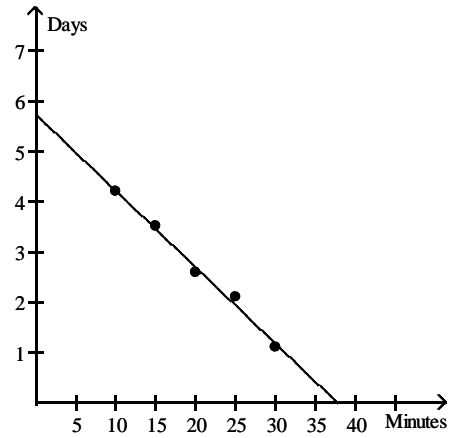

0.1 day

C)

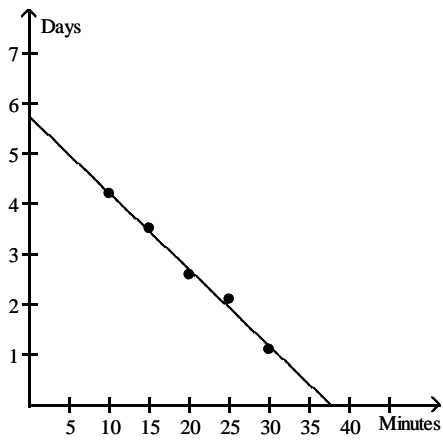

5.8 days

D)

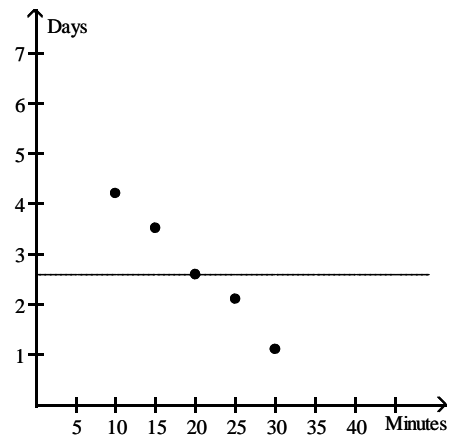

2.6 days

Answer: C

25) When exposed to ethylene gas, green bananas will ripen at an accelerated rate. The number of days for ripening becomes shorter for longer exposure times. Assume that the table below gives average ripening times of bananas several different ethylene exposure times.

Exposure time (minutes)	Ripening Time (days)
10	4.3
15	3.2
20	2.7
25	2.1
30	1.3

Plot the data and then find a line approximating the data. With the aid of this line, determine the rate of change of ripening time with respect to exposure time. Round your answer to two significant digits.

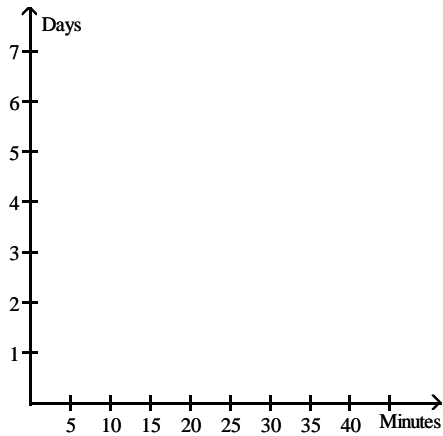

A)

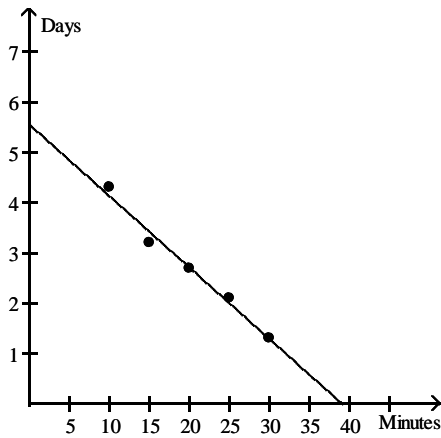

5.6 days

B)

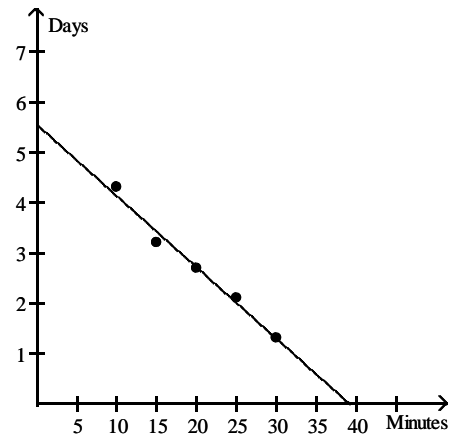

-6.7 days per minute

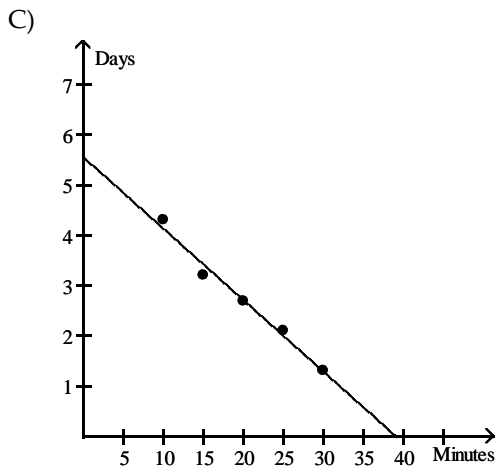

38 minutes

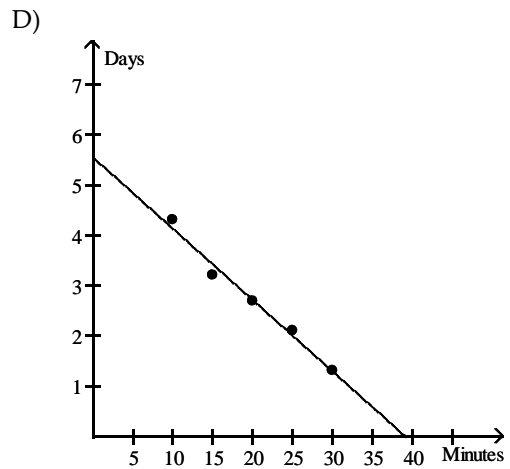

-0.14 day per minute

Answer: D

26) The graph below shows the number of tuberculosis deaths in the United States from 1989 to 1998.

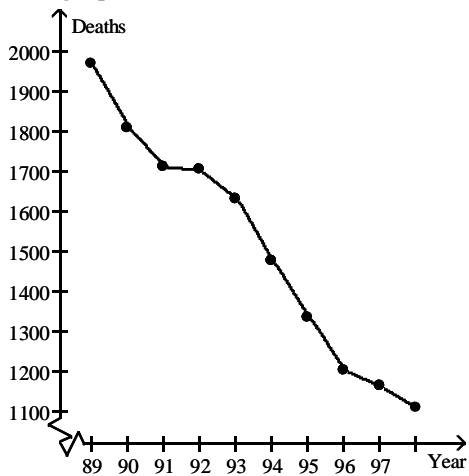

Estimate the average rate of change in tuberculosis deaths from 1996 to 1998.

- A) About -90 deaths per year
- C) About -20 deaths per year

- B) About -0.5 deaths per year
- D) About -50 deaths per year

Answer: D

Use the graph to evaluate the limit.

27) $\lim_{x \rightarrow -1} f(x)$

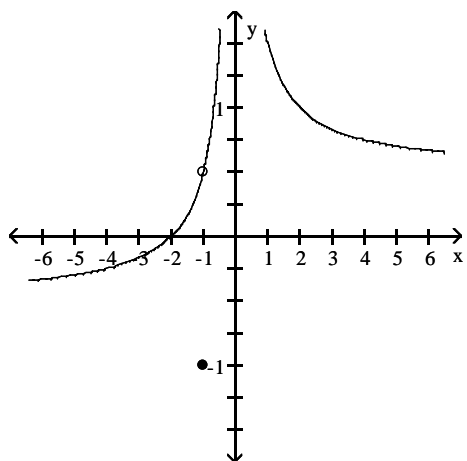

A) $\frac{1}{2}$

B) ∞

C) -1

D) $-\frac{1}{2}$

Answer: A

28) $\lim_{x \rightarrow 0} f(x)$

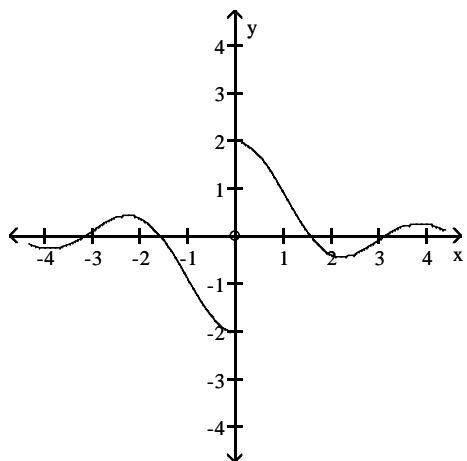

A) 2

B) 0

C) -2

D) does not exist

Answer: D

29) $\lim_{x \rightarrow 0} f(x)$

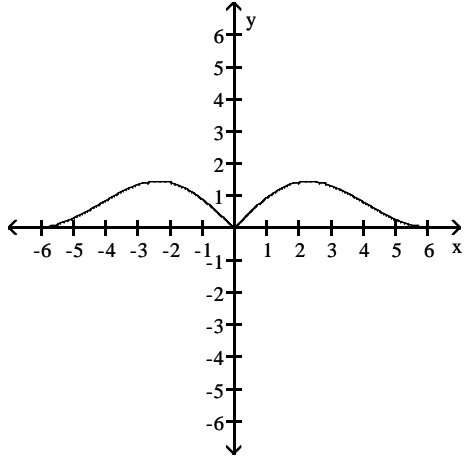

A) does not exist

B) 2

C) 0

D) -2

Answer: C

30) $\lim_{x \rightarrow 0} f(x)$

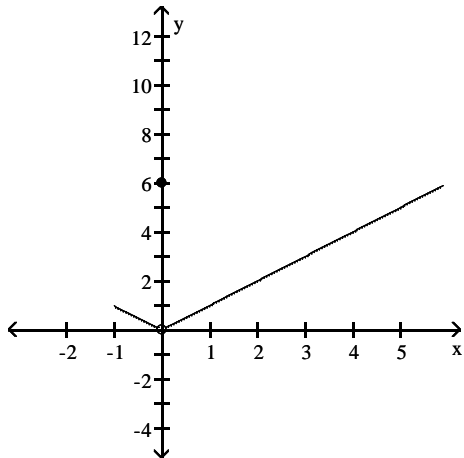

A) -1

B) 6

C) 0

D) does not exist

Answer: C

31) $\lim_{x \rightarrow 0} f(x)$

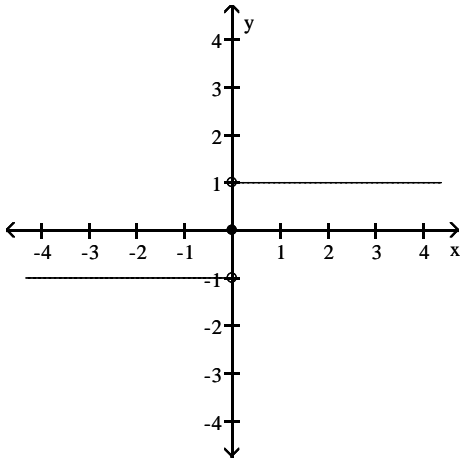

A) does not exist

B) 1

C) ∞

D) -1

Answer: A

32) $\lim_{x \rightarrow 0} f(x)$

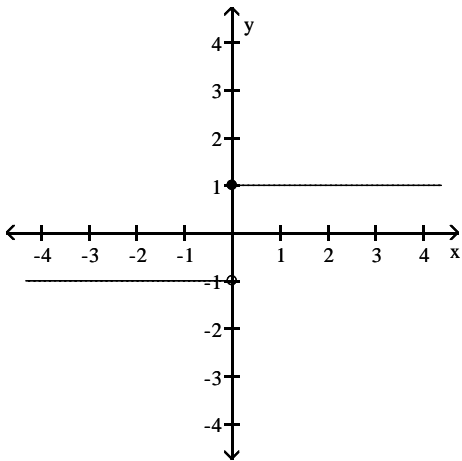

A) 1

B) ∞

C) does not exist

D) -1

Answer: C

33) $\lim_{x \rightarrow 0} f(x)$

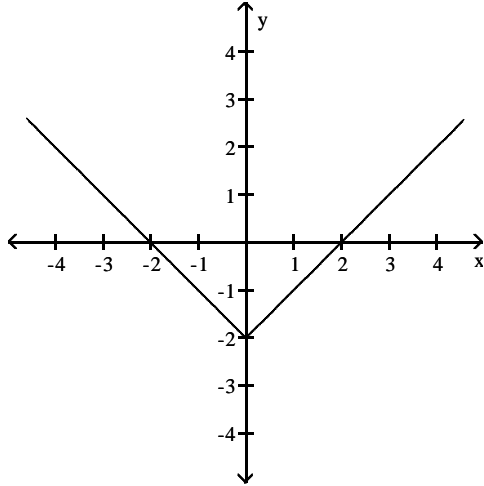

A) does not exist

B) -2

C) 2

D) 0

Answer: B

34) $\lim_{x \rightarrow 0} f(x)$

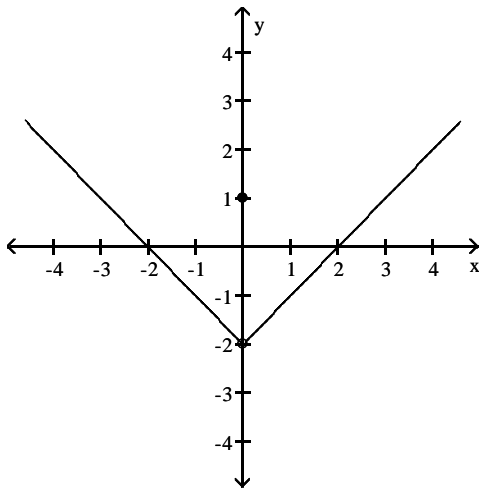

A) 1

B) 0

C) -2

D) does not exist

Answer: C

35) $\lim_{x \rightarrow 0} f(x)$

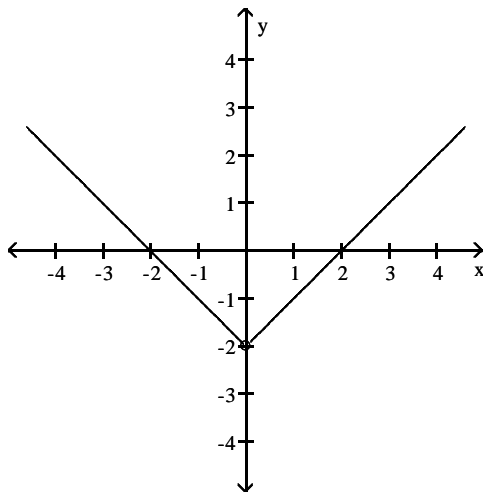

A) does not exist

B) -1

C) 2

D) -2

Answer: D

36) $\lim_{x \rightarrow 0} f(x)$

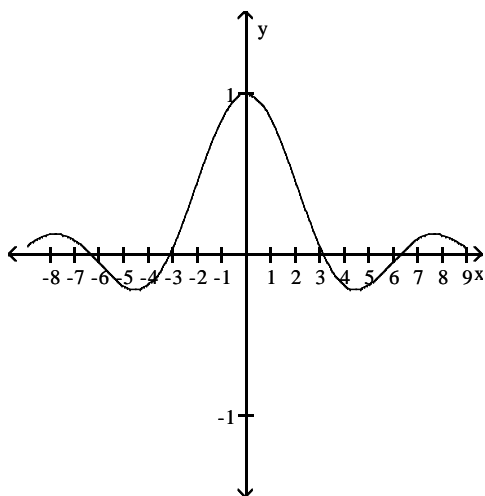

A) 0

B) -1

C) does not exist

D) 1

Answer: D

Find the limit.

37) $\lim_{x \rightarrow 6} (9x + 5)$

A) -49

B) 59

C) 14

D) 5

Answer: B

38) $\lim_{x \rightarrow 2} (x^2 + 8x - 2)$

A) 18

B) 0

C) -18

D) does not exist

Answer: A

39) $\lim_{x \rightarrow 0} (x^2 - 5)$

A) 5

B) does not exist

C) 0

D) -5

Answer: D

40) $\lim_{x \rightarrow 0} (\sqrt{x} - 2)$

A) 0

B) -2

C) 2

D) does not exist

Answer: B

41) $\lim_{x \rightarrow 2} (x^3 + 5x^2 - 7x + 1)$

A) 0

B) does not exist

C) 15

D) 29

Answer: C

42) $\lim_{x \rightarrow -2} (3x^5 - 2x^4 - 4x^3 + x^2 - 5)$

A) -33

B) -161

C) 47

D) -97

Answer: D

43) $\lim_{x \rightarrow 2} \sqrt{x^2 + 2x + 1}$

A) does not exist

B) ± 3

C) 9

D) 3

Answer: D

44) $\lim_{x \rightarrow -1} \frac{x}{3x + 2}$

A) $-\frac{1}{5}$

B) 0

C) does not exist

D) 1

Answer: D

Find the limit if it exists.

45) $\lim_{x \rightarrow 14} \sqrt{5}$

A) $\sqrt{5}$

B) 14

C) 5

D) $\sqrt{14}$

Answer: A

46) $\lim_{x \rightarrow -9} (7x - 3)$

A) 60

B) 66

C) -60

D) -66

Answer: D

47) $\lim_{x \rightarrow -7} (3 - 10x)$

A) 73

B) -73

C) 67

D) -67

Answer: A

48) $\lim_{x \rightarrow 8} (3x^2 - 3x - 10)$

A) 206

B) 158

C) 178

D) 226

Answer: B

49) $\lim_{x \rightarrow -6} 5x(x + 7)(x - 5)$

A) 30

B) -4290

C) 330

D) -330

Answer: C

50) $\lim_{x \rightarrow \frac{2}{5}} 5x \left(x - \frac{1}{3} \right)$

A) $\frac{2}{75}$

B) $\frac{2}{15}$

C) $\frac{22}{15}$

D) $\frac{1}{3}$

Answer: B

51) $\lim_{x \rightarrow 27} x^{2/3}$

A) $\frac{2}{3}$

B) 27

C) 9

D) 18

Answer: C

52) $\lim_{x \rightarrow 1} (x + 2)^2(x - 2)^3$

A) 243

B) -1

C) 27

D) -9

Answer: D

53) $\lim_{x \rightarrow -8} \sqrt{2x + 21}$

A) -5

B) $\sqrt{5}$

C) $-\sqrt{5}$

D) 5

Answer: B

54) $\lim_{x \rightarrow -5} (x + 248)^{3/5}$

A) -27

B) 9

C) 27

D) 81

Answer: C

Find the limit, if it exists.

55) $\lim_{x \rightarrow 8} \frac{1}{x - 8}$

A) 0

B) Does not exist

C) 16

D) 8

Answer: B

56) $\lim_{x \rightarrow 0} \frac{x^3 - 6x + 8}{x - 2}$

A) Does not exist

B) -4

C) 0

D) 4

Answer: B

57) $\lim_{x \rightarrow 1} \frac{2x - 7}{4x + 5}$

A) $-\frac{7}{5}$

B) $-\frac{5}{9}$

C) $-\frac{1}{2}$

D) Does not exist

Answer: B

58) $\lim_{x \rightarrow 1} \frac{3x^2 + 7x - 2}{3x^2 - 4x - 2}$

A) Does not exist

B) $-\frac{8}{3}$

C) 0

D) $-\frac{7}{4}$

Answer: B

59) $\lim_{x \rightarrow 6} \frac{x + 6}{(x - 6)^2}$

A) -6

B) 0

C) 6

D) Does not exist

Answer: D

60) $\lim_{x \rightarrow 5} \frac{x^2 - 2x - 15}{x + 3}$

A) 5

B) 0

C) Does not exist

D) -8

Answer: B

61) $\lim_{h \rightarrow 0} \frac{2}{\sqrt{3h+4} + 2}$

A) 1

B) 1/2

C) 2

D) Does not exist

Answer: B

62) $\lim_{h \rightarrow 0} \frac{19x + h}{x^3(x - h)}$

A) Does not exist

B) $\frac{19}{x^4}$

C) $\frac{19}{x^3}$

D) 19x

Answer: C

63) $\lim_{x \rightarrow 0} \frac{\sqrt{1+x} - 1}{x}$

A) 1/4

B) 0

C) Does not exist

D) 1/2

Answer: D

64) $\lim_{h \rightarrow 0} \frac{(1+h)^{1/3} - 1}{h}$

A) 0

B) Does not exist

C) 3

D) 1/3

Answer: D

65) $\lim_{x \rightarrow 0} \frac{x^3 + 12x^2 - 5x}{5x}$

A) -1

B) 5

C) Does not exist

D) 0

Answer: A

66) $\lim_{x \rightarrow 1} \frac{x^4 - 1}{x - 1}$

A) 4

B) 2

C) Does not exist

D) 0

Answer: A

67) $\lim_{x \rightarrow 4} \frac{x^2 - 16}{x - 4}$

A) 8

B) 4

C) 1

D) Does not exist

Answer: A

68) $\lim_{x \rightarrow -4} \frac{x^2 + 9x + 20}{x + 4}$

A) 72

B) 9

C) Does not exist

D) 1

Answer: D

69) $\lim_{x \rightarrow 1} \frac{x^2 + 2x - 3}{x - 1}$

A) 2

B) 4

C) Does not exist

D) 0

Answer: B

70) $\lim_{x \rightarrow 1} \frac{x^2 + 8x - 9}{x^2 - 1}$

A) 5

B) 0

C) - 4

D) Does not exist

Answer: A

71) $\lim_{x \rightarrow 5} \frac{x^2 - 25}{x^2 - 9x + 20}$

A) Does not exist

B) 0

C) 10

D) 5

Answer: C

72) $\lim_{x \rightarrow 1} \frac{x^2 - 4x + 3}{x^2 - 5x + 4}$

A) Does not exist

B) $-\frac{2}{3}$

C) $\frac{2}{3}$

D) $-\frac{4}{3}$

Answer: C

73) $\lim_{h \rightarrow 0} \frac{(x+h)^3 - x^3}{h}$

A) $3x^2$

B) $3x^2 + 3xh + h^2$

C) 0

D) Does not exist

Answer: A

74) $\lim_{x \rightarrow 11} \frac{|11-x|}{11-x}$

A) 1

B) 0

C) Does not exist

D) -1

Answer: C

Find the limit.

75) $\lim_{x \rightarrow 0} (5 \sin x - 1)$

A) -1

B) $5 - 1$

C) 0

D) 5

Answer: C

76) $\lim_{x \rightarrow \pi} \sqrt{x+7} \cos(x + \pi)$

A) $-\sqrt{7-\pi}$

B) $\sqrt{7-\pi}$

C) 1

D) 0

Answer: B

77) $\lim_{x \rightarrow 0} \sqrt{8 + \cos^2 x}$

A) $2\sqrt{2}$

B) 3

C) 8

D) 9

Answer: B

93) $f(x) = 4\sqrt{x}$, $x = 4$

A) 1

B) Does not exist

C) 8

D) 4

Answer: A

94) $f(x) = \sqrt{x}$, $x = 13$

A) $\frac{\sqrt{13}}{26}$

B) $\frac{\sqrt{13}}{13}$

C) $\frac{13}{2}$

D) Does not exist

Answer: A

95) $f(x) = 2\sqrt{x} + 10$, $x = 25$

A) 25

B) $\frac{1}{5}$

C) Does not exist

D) 5

Answer: B

Provide an appropriate response.

96) It can be shown that the inequalities $-x \leq x \cos\left(\frac{1}{x}\right) \leq x$ hold for all values of $x \geq 0$.

Find $\lim_{x \rightarrow 0} x \cos\left(\frac{1}{x}\right)$ if it exists.

A) 1

B) does not exist

C) 0.0007

D) 0

Answer: D

97) The inequality $1 - \frac{x^2}{2} < \frac{\sin x}{x} < 1$ holds when x is measured in radians and $|x| < 1$.

Find $\lim_{x \rightarrow 0} \frac{\sin x}{x}$ if it exists.

A) does not exist

B) 1

C) 0

D) 0.0007

Answer: B

98) If $x^3 \leq f(x) \leq x$ for x in $[-1, 1]$, find $\lim_{x \rightarrow 0} f(x)$ if it exists.

A) does not exist

B) 1

C) -1

D) 0

Answer: D

Use the table of values of f to estimate the limit.

99) Let $f(x) = x^2 + 8x - 2$, find $\lim_{x \rightarrow 2} f(x)$.

x	1.9	1.99	1.999	2.001	2.01	2.1
$f(x)$						

A)

x	1.9	1.99	1.999	2.001	2.01	2.1
$f(x)$	5.043	5.364	5.396	5.404	5.436	5.763

; limit = 5.40

B)

x	1.9	1.99	1.999	2.001	2.01	2.1
$f(x)$	5.043	5.364	5.396	5.404	5.436	5.763

; limit = ∞

C)

x	1.9	1.99	1.999	2.001	2.01	2.1
$f(x)$	16.810	17.880	17.988	18.012	18.120	19.210

; limit = 18.0

D)

x	1.9	1.99	1.999	2.001	2.01	2.1
$f(x)$	16.692	17.592	17.689	17.710	17.808	18.789

; limit = 17.70

Answer: C

100) Let $f(x) = \frac{x-4}{\sqrt{x}-2}$, find $\lim_{x \rightarrow 4} f(x)$.

x	3.9	3.99	3.999	4.001	4.01	4.1
$f(x)$						

A)

x	3.9	3.99	3.999	4.001	4.01	4.1
$f(x)$	1.19245	1.19925	1.19993	1.20007	1.20075	1.20745

; limit = ∞

B)

x	3.9	3.99	3.999	4.001	4.01	4.1
$f(x)$	1.19245	1.19925	1.19993	1.20007	1.20075	1.20745

; limit = 1.20

C)

x	3.9	3.99	3.999	4.001	4.01	4.1
$f(x)$	3.97484	3.99750	3.99975	4.00025	4.00250	4.02485

; limit = 4.0

D)

x	3.9	3.99	3.999	4.001	4.01	4.1
$f(x)$	5.07736	5.09775	5.09978	5.10022	5.10225	5.12236

; limit = 5.10

Answer: C

101) Let $f(x) = x^2 - 5$, find $\lim_{x \rightarrow 0} f(x)$.

x	-0.1	-0.01	-0.001	0.001	0.01	0.1
f(x)						

A)

x	-0.1	-0.01	-0.001	0.001	0.01	0.1
f(x)	-4.9900	-4.9999	-5.0000	-5.0000	-4.9999	-4.9900

; limit = -5.0

B)

x	-0.1	-0.01	-0.001	0.001	0.01	0.1
f(x)	-1.4970	-1.4999	-1.5000	-1.5000	-1.4999	-1.4970

; limit = ∞

C)

x	-0.1	-0.01	-0.001	0.001	0.01	0.1
f(x)	-2.9910	-2.9999	-3.0000	-3.0000	-2.9999	-2.9910

; limit = -3.0

D)

x	-0.1	-0.01	-0.001	0.001	0.01	0.1
f(x)	-1.4970	-1.4999	-1.5000	-1.5000	-1.4999	-1.4970

; limit = -15.0

Answer: A

102) Let $f(x) = \frac{x-2}{x^2-6x+8}$, find $\lim_{x \rightarrow 2} f(x)$.

x	1.9	1.99	1.999	2.001	2.01	2.1
f(x)						

A)

x	1.9	1.99	1.999	2.001	2.01	2.1
f(x)	-0.3762	-0.3975	-0.3998	-0.4003	-0.4025	-0.4263

; limit = -0.4

B)

x	1.9	1.99	1.999	2.001	2.01	2.1
f(x)	-0.4762	-0.4975	-0.4998	-0.5003	-0.5025	-0.5263

; limit = -0.5

C)

x	1.9	1.99	1.999	2.001	2.01	2.1
f(x)	-0.5762	-0.5975	-0.5998	-0.6003	-0.6025	-0.6263

; limit = -0.6

D)

x	1.9	1.99	1.999	2.001	2.01	2.1
f(x)	0.4762	0.4975	0.4998	0.5003	0.5025	0.5263

; limit = 0.5

Answer: B

103) Let $f(x) = \frac{x^2 + 7x + 12}{x^2 + 5x + 4}$, find $\lim_{x \rightarrow -4} f(x)$.

x	-4.1	-4.01	-4.001	-3.999	-3.99	-3.9
f(x)						

A)

x	-4.1	-4.01	-4.001	-3.999	-3.99	-3.9
f(x)	0.4548	0.4355	0.4336	0.4331	0.4311	0.4103

; limit = 0.4333

B)

x	-4.1	-4.01	-4.001	-3.999	-3.99	-3.9
f(x)	1.4082	1.4008	1.4001	1.3999	1.3992	1.3922

; limit = 1.4

C)

x	-4.1	-4.01	-4.001	-3.999	-3.99	-3.9
f(x)	0.2548	0.2355	0.2336	0.2331	0.2311	0.2103

; limit = 0.2333

D)

x	-4.1	-4.01	-4.001	-3.999	-3.99	-3.9
f(x)	0.3548	0.3355	0.3336	0.3331	0.3311	0.3103

; limit = 0.3333

Answer: D

104) Let $f(x) = \frac{\sin(3x)}{x}$, find $\lim_{x \rightarrow 0} f(x)$.

x	-0.1	-0.01	-0.001	0.001	0.01	0.1
f(x)		2.99955002			2.99955002	

A) limit = 3

B) limit = 2.5

C) limit does not exist

D) limit = 0

Answer: A

105) Let $f(\theta) = \frac{\cos(5\theta)}{\theta}$, find $\lim_{\theta \rightarrow 0} f(\theta)$.

x	-0.1	-0.01	-0.001	0.001	0.01	0.1
f(θ)	-8.7758256					8.7758256

A) limit does not exist

B) limit = 0

C) limit = 5

D) limit = 8.7758256

Answer: A

Find the limit.

106) If $\lim_{x \rightarrow 3} \frac{f(x) - 4}{x - 2} = 3$, find $\lim_{x \rightarrow 3} f(x)$.

A) 3

B) 11

C) 7

D) Does not exist

Answer: C

107) If $\lim_{x \rightarrow 2} \frac{f(x)}{x} = 3$, find $\lim_{x \rightarrow 2} f(x)$.

A) 3

B) 6

C) 2

D) Does not exist

Answer: B

116) $\lim_{x \rightarrow 0} \frac{\sqrt{9+2x} - 3}{x}$

A) $\frac{1}{6}$

B) 9

C) $\frac{2}{3}$

D) $\frac{1}{3}$

Answer: D

117) $\lim_{x \rightarrow 0} \frac{\sqrt{10+10x} - \sqrt{10}}{x}$

A) $\sqrt{10}$

B) $\frac{1}{2}$

C) $\frac{\sqrt{10}}{2}$

D) 0

Answer: C

118) $\lim_{x \rightarrow 0} \frac{6 - \sqrt{36 - x^2}}{x}$

A) 12

B) $\frac{1}{6}$

C) 0

D) $\frac{1}{12}$

Answer: C

119) $\lim_{x \rightarrow 3} \frac{x^2 - 9}{\sqrt{x^2 + 7} - 4}$

A) 8

B) 3

C) $\frac{1}{4}$

D) 4

Answer: A

120) $\lim_{x \rightarrow -1} \frac{x^2 - 1}{\sqrt{x^2 + 3} - 2}$

A) $\frac{1}{4}$

B) 4

C) 2

D) 1

Answer: B

SHORT ANSWER. Write the word or phrase that best completes each statement or answers the question.

Provide an appropriate response.

121) It can be shown that the inequalities $1 - \frac{x^2}{6} < \frac{x \sin(x)}{2 - 2 \cos(x)} < 1$ hold for all values of x close to zero. What, if anything, does this tell you about $\frac{x \sin(x)}{2 - 2 \cos(x)}$? Explain.

Answer: Answers may vary. One possibility: $\lim_{x \rightarrow 0} 1 - \frac{x^2}{6} = \lim_{x \rightarrow 0} 1 = 1$. According to the squeeze theorem, the

function $\frac{x \sin(x)}{2 - 2 \cos(x)}$, which is squeezed between $1 - \frac{x^2}{6}$ and 1, must also approach 1 as x approaches 0.

Thus, $\lim_{x \rightarrow 0} \frac{x \sin(x)}{2 - 2 \cos(x)} = 1$.

MULTIPLE CHOICE. Choose the one alternative that best completes the statement or answers the question.

122) Write the formal notation for the principle "the limit of a quotient is the quotient of the limits" and include a statement of any restrictions on the principle.

A) $\lim_{x \rightarrow a} \frac{g(x)}{f(x)} = \frac{g(a)}{f(a)}$, provided that $f(a) \neq 0$.

B) $\lim_{x \rightarrow a} \frac{g(x)}{f(x)} = \frac{g(a)}{f(a)}$.

C) If $\lim_{x \rightarrow a} g(x) = M$ and $\lim_{x \rightarrow a} f(x) = L$, then $\lim_{x \rightarrow a} \frac{g(x)}{f(x)} = \frac{\lim_{x \rightarrow a} g(x)}{\lim_{x \rightarrow a} f(x)} = \frac{M}{L}$, provided that $L \neq 0$.

D) If $\lim_{x \rightarrow a} g(x) = M$ and $\lim_{x \rightarrow a} f(x) = L$, then $\lim_{x \rightarrow a} \frac{g(x)}{f(x)} = \frac{\lim_{x \rightarrow a} g(x)}{\lim_{x \rightarrow a} f(x)} = \frac{M}{L}$, provided that $f(a) \neq 0$.

Answer: C

123) What conditions, when present, are sufficient to conclude that a function $f(x)$ has a limit as x approaches some value of a ?

A) The limit of $f(x)$ as $x \rightarrow a$ from the left exists, the limit of $f(x)$ as $x \rightarrow a$ from the right exists, and at least one of these limits is the same as $f(a)$.

B) $f(a)$ exists, the limit of $f(x)$ as $x \rightarrow a$ from the left exists, and the limit of $f(x)$ as $x \rightarrow a$ from the right exists.

C) Either the limit of $f(x)$ as $x \rightarrow a$ from the left exists or the limit of $f(x)$ as $x \rightarrow a$ from the right exists

D) The limit of $f(x)$ as $x \rightarrow a$ from the left exists, the limit of $f(x)$ as $x \rightarrow a$ from the right exists, and these two limits are the same.

Answer: D

124) Provide a short sentence that summarizes the general limit principle given by the formal notation

$$\lim_{x \rightarrow a} [f(x) \pm g(x)] = \lim_{x \rightarrow a} f(x) \pm \lim_{x \rightarrow a} g(x) = L \pm M, \text{ given that } \lim_{x \rightarrow a} f(x) = L \text{ and } \lim_{x \rightarrow a} g(x) = M.$$

A) The sum or the difference of two functions is the sum of two limits.

B) The limit of a sum or a difference is the sum or the difference of the functions.

C) The sum or the difference of two functions is continuous.

D) The limit of a sum or a difference is the sum or the difference of the limits.

Answer: D

125) The statement "the limit of a constant times a function is the constant times the limit" follows from a combination of two fundamental limit principles. What are they?

A) The limit of a product is the product of the limits, and the limit of a quotient is the quotient of the limits.

B) The limit of a product is the product of the limits, and a constant is continuous.

C) The limit of a function is a constant times a limit, and the limit of a constant is the constant.

D) The limit of a constant is the constant, and the limit of a product is the product of the limits.

Answer: D

Given the interval (a, b) on the x -axis with the point c inside, find the greatest value for $\delta > 0$ such that for all x , $0 < |x - c| < \delta \Rightarrow a < x < b$.

126) $a = -2, b = 8, c = 1$

A) $\delta = 4$

B) $\delta = 1$

C) $\delta = 3$

D) $\delta = 7$

Answer: C

127) $a = \frac{3}{9}, b = \frac{8}{9}, c = \frac{4}{9}$

A) $\delta = 1$

B) $\delta = \frac{4}{9}$

C) $\delta = \frac{1}{9}$

D) $\delta = 0$

Answer: C

128) $a = 1.348, b = 2.804, c = 1.869$

A) $\delta = 1.456$

B) $\delta = 0.521$

C) $\delta = 0.935$

D) $\delta = 1$

Answer: B

Use the graph to find a $\delta > 0$ such that for all $x, 0 < |x - c| < \delta \Rightarrow |f(x) - L| < \epsilon$.

129)

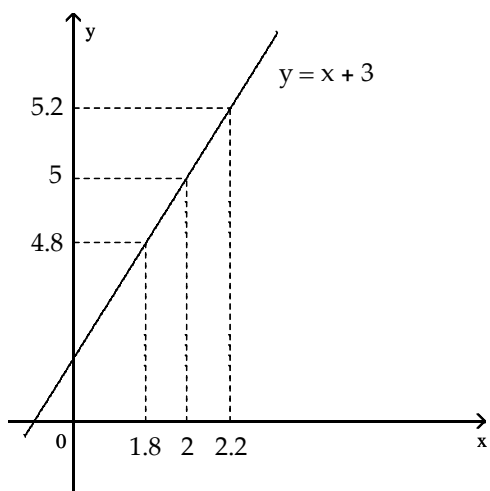

$f(x) = x + 3$
 $c = 2$
 $L = 5$
 $\epsilon = 0.2$

NOT TO SCALE

A) $\delta = 3$

B) $\delta = 0.1$

C) $\delta = 0.4$

D) $\delta = 0.2$

Answer: D

130)

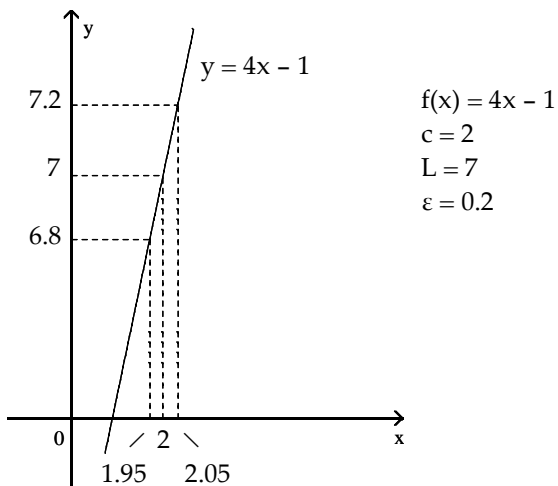

NOT TO SCALE

A) $\delta = 0.1$

B) $\delta = 5$

C) $\delta = 0.05$

D) $\delta = 0.5$

Answer: C

131)

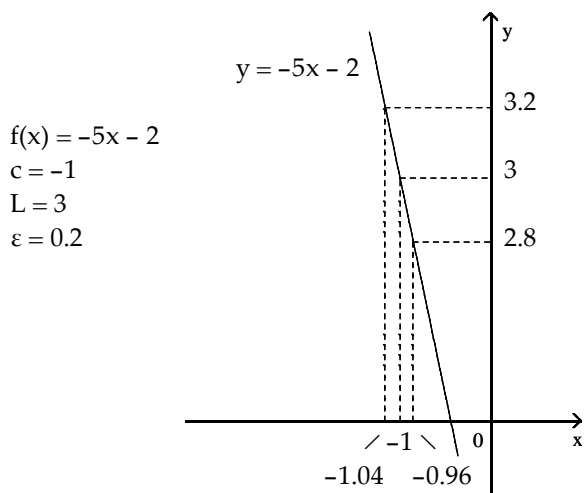

NOT TO SCALE

A) $\delta = -0.04$

B) $\delta = 0.04$

C) $\delta = 8$

D) $\delta = 0.4$

Answer: B

132)

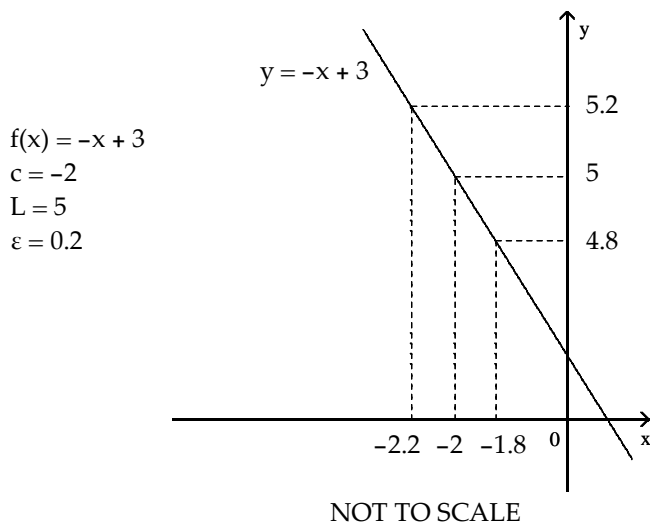

A) $\delta = 7$

B) $\delta = -0.2$

C) $\delta = 0.4$

D) $\delta = 0.2$

Answer: D

133)

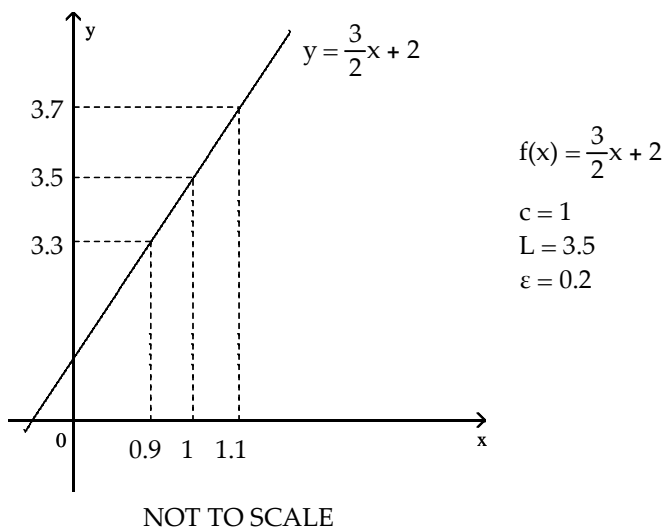

$f(x) = \frac{3}{2}x + 2$

$c = 1$
 $L = 3.5$
 $\varepsilon = 0.2$

A) $\delta = 2.5$

B) $\delta = -0.2$

C) $\delta = 0.1$

D) $\delta = 0.2$

Answer: C

134)

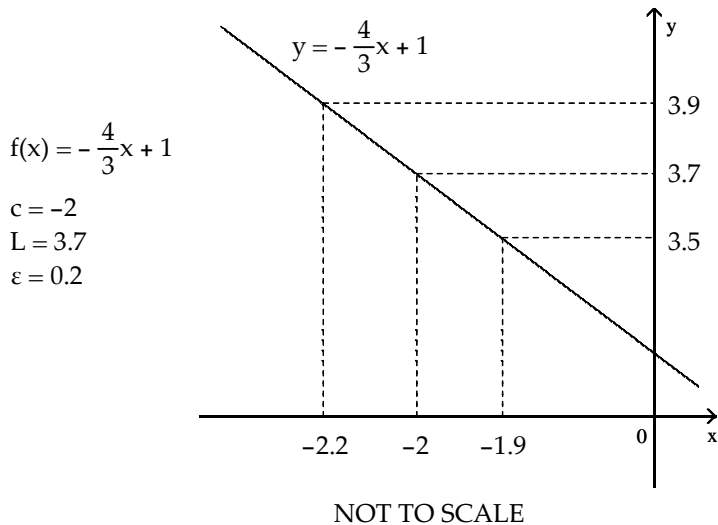

A) $\delta = 0.1$

B) $\delta = 0.3$

C) $\delta = -0.3$

D) $\delta = 5.7$

Answer: A

135)

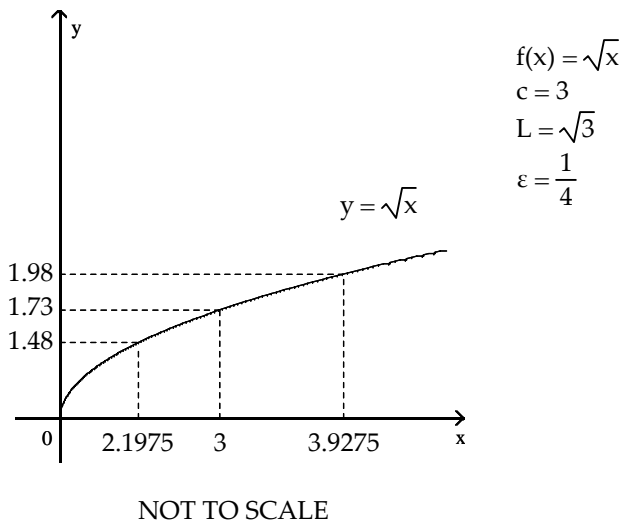

A) $\delta = -1.27$

B) $\delta = 1.73$

C) $\delta = 0.8025$

D) $\delta = 0.9275$

Answer: C

136)

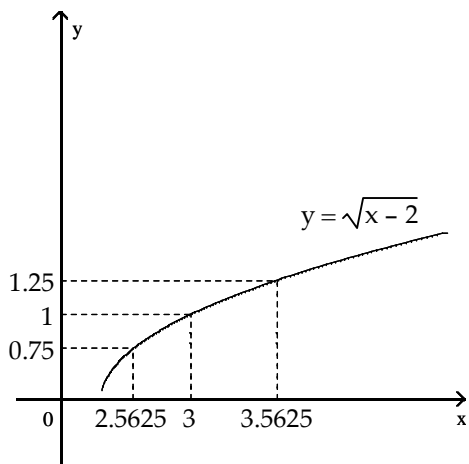

$$f(x) = \sqrt{x-2}$$

$$c = 3$$

$$L = 1$$

$$\varepsilon = \frac{1}{4}$$

NOT TO SCALE

A) $\delta = 0.4375$

B) $\delta = 1$

C) $\delta = 2$

D) $\delta = 0.5625$

Answer: A

137)

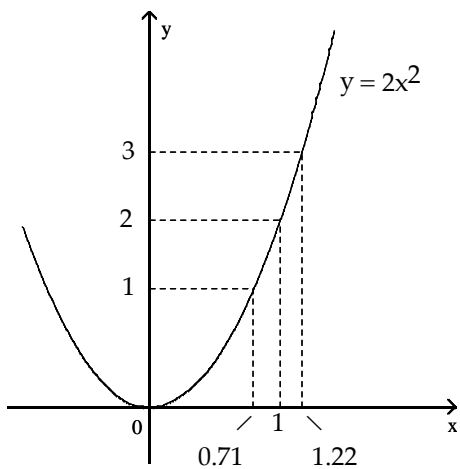

$$f(x) = 2x^2$$

$$c = 1$$

$$L = 2$$

$$\varepsilon = 1$$

NOT TO SCALE

A) $\delta = 0.29$

B) $\delta = 0.51$

C) $\delta = 0.22$

D) $\delta = 1$

Answer: C

138)

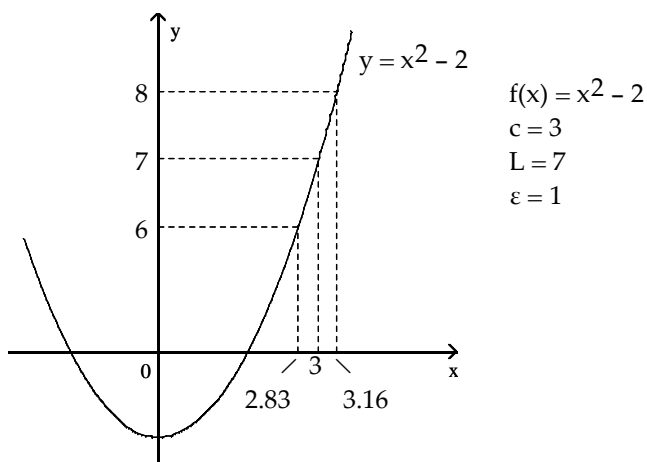

NOT TO SCALE

A) $\delta = 0.17$

B) $\delta = 0.16$

C) $\delta = 0.33$

D) $\delta = 4$

Answer: B

A function $f(x)$, a point c , the limit of $f(x)$ as x approaches c , and a positive number ϵ is given. Find a number $\delta > 0$ such that for all x , $0 < |x - c| < \delta \Rightarrow |f(x) - L| < \epsilon$.

139) $f(x) = 4x + 1$, $L = 13$, $c = 3$, and $\epsilon = 0.01$

A) $\delta = 0.0125$

B) $\delta = 0.003333$

C) $\delta = 0.0025$

D) $\delta = 0.005$

Answer: C

140) $f(x) = 8x - 9$, $L = 15$, $c = 3$, and $\epsilon = 0.01$

A) $\delta = 0.000625$

B) $\delta = 0.003333$

C) $\delta = 0.0025$

D) $\delta = 0.00125$

Answer: D

141) $f(x) = -4x + 9$, $L = -3$, $c = 3$, and $\epsilon = 0.01$

A) $\delta = -0.003333$

B) $\delta = 0.0025$

C) $\delta = 0.01$

D) $\delta = 0.005$

Answer: B

142) $f(x) = -3x - 7$, $L = -19$, $c = 4$, and $\epsilon = 0.01$

A) $\delta = 0.006667$

B) $\delta = 0.003333$

C) $\delta = -0.0025$

D) $\delta = 0.001667$

Answer: B

143) $f(x) = \sqrt{x + 2}$, $L = 3$, $c = 7$, and $\epsilon = 1$

A) $\delta = 16$

B) $\delta = 5$

C) $\delta = 4$

D) $\delta = 7$

Answer: B

144) $f(x) = \sqrt{17 - x}$, $L = 4$, $c = 1$, and $\epsilon = 1$

A) $\delta = -9$

B) $\delta = 8$

C) $\delta = 12$

D) $\delta = 7$

Answer: D

145) $f(x) = 7x^2$, $L = 175$, $c = 5$, and $\epsilon = 0.5$

A) $\delta = 4.99285$

B) $\delta = 0.00715$

C) $\delta = 5.00714$

D) $\delta = 0.00714$

Answer: D

146) $f(x) = \frac{1}{x}$, $L = \frac{1}{2}$, $c = 2$, and $\epsilon = 0.3$

A) $\delta = 0.375$

B) $\delta = 0.75$

C) $\delta = 10$

D) $\delta = 3$

Answer: B

147) $f(x) = mx$, $m > 0$, $L = 4m$, $c = 4$, and $\epsilon = 0.05$

A) $\delta = 0.05$

B) $\delta = \frac{0.05}{m}$

C) $\delta = 4 + \frac{0.05}{m}$

D) $\delta = 4 - m$

Answer: B

148) $f(x) = mx + b$, $m > 0$, $L = \frac{m}{5} + b$, $c = \frac{1}{5}$, and $\epsilon = c > 0$

A) $\delta = \frac{1}{5} + \frac{c}{m}$

B) $\delta = \frac{c}{m}$

C) $\delta = \frac{c}{5}$

D) $\delta = \frac{5}{m}$

Answer: B

Find the limit L for the given function f , the point c , and the positive number ϵ . Then find a number $\delta > 0$ such that, for all x , $0 < |x - c| < \delta \Rightarrow |f(x) - L| < \epsilon$.

149) $f(x) = -3x + 8$, $c = -2$, $\epsilon = 0.03$

A) $L = 2$; $\delta = 0.02$

B) $L = -2$; $\delta = 0.01$

C) $L = 14$; $\delta = 0.01$

D) $L = 14$; $\delta = 0.02$

Answer: C

150) $f(x) = \frac{x^2 + -16x + 60}{x + -6}$, $c = 6$, $\epsilon = 0.02$

A) $L = 0$; $\delta = 0.02$

B) $L = -4$; $\delta = 0.02$

C) $L = -16$; $\delta = 0.03$

D) $L = -20$; $\delta = 0.03$

Answer: B

151) $f(x) = \sqrt{58 - 3x}$, $c = -2$, $\epsilon = 0.2$

A) $L = 8$; $\delta = 1.08$

B) $L = -7$; $\delta = 0.52$

C) $L = 8$; $\delta = 1.05$

D) $L = 9$; $\delta = 1.05$

Answer: C

152) $f(x) = \frac{14}{x}$, $c = 7$, $\epsilon = 0.4$

A) $L = 2$; $\delta = 17.5$

B) $L = 2$; $\delta = 1.17$

C) $L = 2$; $\delta = 1.75$

D) $L = 2$; $\delta = 3.5$

Answer: C

SHORT ANSWER. Write the word or phrase that best completes each statement or answers the question.

Prove the limit statement

153) $\lim_{x \rightarrow 1} (2x - 5) = -3$

Answer:

Let $\epsilon > 0$ be given. Choose $\delta = \epsilon/2$. Then $0 < |x - 1| < \delta$ implies that

$$\begin{aligned} |(2x - 5) + 3| &= |2x - 2| \\ &= |2(x - 1)| \\ &= 2|x - 1| < 2\delta = \epsilon \end{aligned}$$

Thus, $0 < |x - 1| < \delta$ implies that $|(2x - 5) + 3| < \epsilon$

$$154) \lim_{x \rightarrow 7} \frac{x^2 - 49}{x - 7} = 14$$

Answer: Let $\varepsilon > 0$ be given. Choose $\delta = \varepsilon$. Then $0 < |x - 7| < \delta$ implies that

$$\begin{aligned} \left| \frac{x^2 - 49}{x - 7} - 14 \right| &= \left| \frac{(x - 7)(x + 7)}{x - 7} - 14 \right| \\ &= |(x + 7) - 14| \quad \text{for } x \neq 7 \\ &= |x - 7| < \delta = \varepsilon \end{aligned}$$

$$\text{Thus, } 0 < |x - 7| < \delta \text{ implies that } \left| \frac{x^2 - 49}{x - 7} - 14 \right| < \varepsilon$$

$$155) \lim_{x \rightarrow 2} \frac{5x^2 - 8x - 4}{x - 2} = 12$$

Answer: Let $\varepsilon > 0$ be given. Choose $\delta = \varepsilon/5$. Then $0 < |x - 2| < \delta$ implies that

$$\begin{aligned} \left| \frac{5x^2 - 8x - 4}{x - 2} - 12 \right| &= \left| \frac{(x - 2)(5x + 2)}{x - 2} - 12 \right| \\ &= |(5x + 2) - 12| \quad \text{for } x \neq 2 \\ &= |5x - 10| \\ &= |5(x - 2)| \\ &= 5|x - 2| < 5\delta = \varepsilon \end{aligned}$$

$$\text{Thus, } 0 < |x - 2| < \delta \text{ implies that } \left| \frac{5x^2 - 8x - 4}{x - 2} - 12 \right| < \varepsilon$$

$$156) \lim_{x \rightarrow 3} \frac{1}{x} = \frac{1}{3}$$

Answer: Let $\varepsilon > 0$ be given. Choose $\delta = \min\{3/2, 9\varepsilon/2\}$. Then $0 < |x - 3| < \delta$ implies that

$$\begin{aligned} \left| \frac{1}{x} - \frac{1}{3} \right| &= \left| \frac{3 - x}{3x} \right| \\ &= \frac{1}{|x|} \cdot \frac{1}{3} \cdot |x - 3| \\ &< \frac{1}{3/2} \cdot \frac{1}{3} \cdot \frac{9\varepsilon}{2} = \varepsilon \end{aligned}$$

$$\text{Thus, } 0 < |x - 3| < \delta \text{ implies that } \left| \frac{1}{x} - \frac{1}{3} \right| < \varepsilon$$

MULTIPLE CHOICE. Choose the one alternative that best completes the statement or answers the question.

Solve the problem.

- 157) You are asked to make some circular cylinders, each with a cross-sectional area of 1 cm^2 . To do this, you need to know how much deviation from the ideal cylinder diameter of $x_0 = 1.99 \text{ cm}$ you can allow and still have the area come within 0.1 cm^2 of the required 1 cm^2 . To find out, let $A = \pi \left(\frac{x}{2} \right)^2$ and look for the interval in which you must hold x to make $|A - 1| < 0.1$. What interval do you find?

A) (0.7569, 0.8368)

B) (1.8974, 2.0976)

C) (0.5642, 0.5642)

D) (1.0705, 1.1835)

Answer: D

158) Ohm's Law for electrical circuits is stated $V = RI$, where V is a constant voltage, R is the resistance in ohms and I is the current in amperes. Your firm has been asked to supply the resistors for a circuit in which V will be 12 volts and I is to be 5 ± 0.1 amperes. In what interval does R have to lie for I to be within 0.1 amps of the target value $I_0 = 5$?

- A) $\left(\frac{40}{17}, \frac{120}{49}\right)$ B) $\left(\frac{10}{49}, \frac{10}{51}\right)$ C) $\left(\frac{120}{49}, \frac{40}{17}\right)$ D) $\left(\frac{17}{40}, \frac{49}{120}\right)$

Answer: A

159) The cross-sectional area of a cylinder is given by $A = \pi D^2/4$, where D is the cylinder diameter. Find the tolerance range of D such that $|A - 10| < 0.01$ as long as $D_{\min} < D < D_{\max}$.

- A) $D_{\min} = 3.558, D_{\max} = 3.578$ B) $D_{\min} = 3.567, D_{\max} = 3.578$
 C) $D_{\min} = 3.558, D_{\max} = 3.570$ D) $D_{\min} = 3.567, D_{\max} = 3.570$

Answer: D

160) The current in a simple electrical circuit is given by $I = V/R$, where I is the current in amperes, V is the voltage in volts, and R is the resistance in ohms. When $V = 12$ volts, what is a 12Ω resistor's tolerance for the current to be within 1 ± 0.01 amp?

- A) 10% B) 1% C) 0.1% D) 0.01%

Answer: B

Provide an appropriate response.

161) The definition of the limit, $\lim_{x \rightarrow c} f(x) = L$, means if given any number $\epsilon > 0$, there exists a number $\delta > 0$, such that

for all x , $0 < |x - c| < \delta$ implies _____.

- A) $|f(x) - L| < \delta$ B) $|f(x) - L| > \delta$ C) $|f(x) - L| > \epsilon$ D) $|f(x) - L| < \epsilon$

Answer: D

162) Identify the incorrect statements about limits.

- I. The number L is the limit of $f(x)$ as x approaches c if $f(x)$ gets closer to L as x approaches x_0 .
- II. The number L is the limit of $f(x)$ as x approaches c if, for any $\epsilon > 0$, there corresponds a $\delta > 0$ such that $|f(x) - L| < \epsilon$ whenever $0 < |x - c| < \delta$.
- III. The number L is the limit of $f(x)$ as x approaches c if, given any $\epsilon > 0$, there exists a value of x for which $|f(x) - L| < \epsilon$.

- A) I and III B) II and III C) I, II, and III D) I and II

Answer: A

Use the graph to estimate the specified limit.

163) Find $\lim_{x \rightarrow (-1)^-} f(x)$ and $\lim_{x \rightarrow (-1)^+} f(x)$

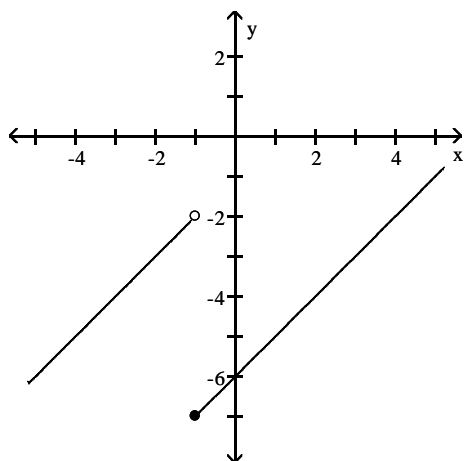

A) -2; -7

B) -7; -2

C) -7; -5

D) -5; -2

Answer: A

164) Find $\lim_{x \rightarrow 0} f(x)$

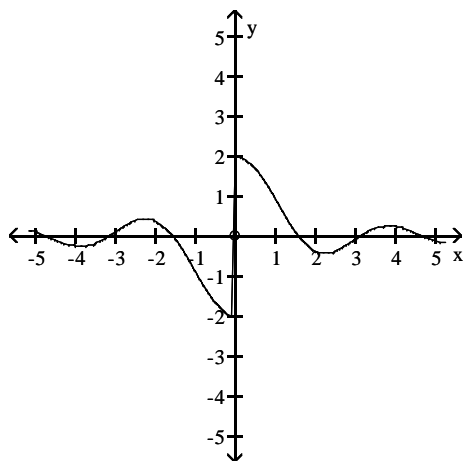

A) 0

B) does not exist

C) 2

D) -2

Answer: B

165) Find $\lim_{x \rightarrow 0} f(x)$

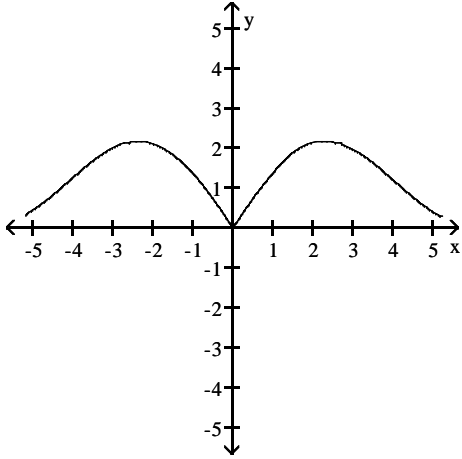

A) 3

B) 0

C) does not exist

D) -3

Answer: B

166) Find $\lim_{x \rightarrow 3^-} f(x)$

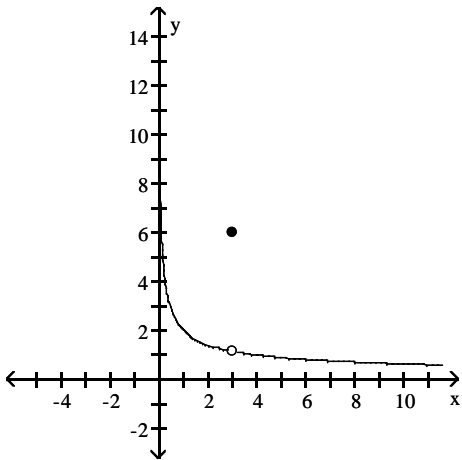

A) $-\frac{2\sqrt{3}}{3}$

B) $\frac{2\sqrt{3}}{3}$

C) $\frac{2}{3}$

D) -3

Answer: B

167) Find $\lim_{x \rightarrow (\pi/2)^-} f(x)$ and $\lim_{x \rightarrow (\pi/2)^+} f(x)$

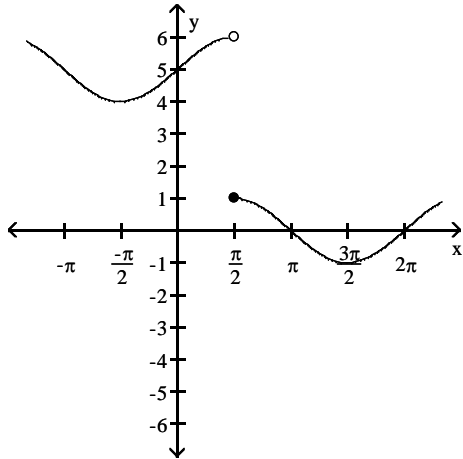

A) 1; 6

B) 6; 1

C) π ; π

D) $\frac{\pi}{2}$; $\frac{\pi}{2}$

Answer: B

168) Find $\lim_{x \rightarrow 0^-} f(x)$ and $\lim_{x \rightarrow 0^+} f(x)$

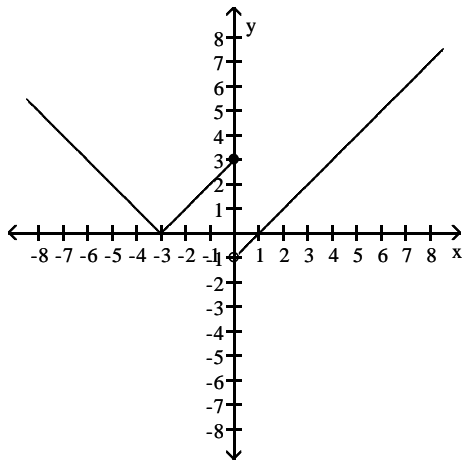

A) 3; 1

B) 3; -1

C) -1; 3

D) -3; -1

Answer: B

169) Find $\lim_{x \rightarrow 2^-} f(x)$ and $\lim_{x \rightarrow 2^+} f(x)$

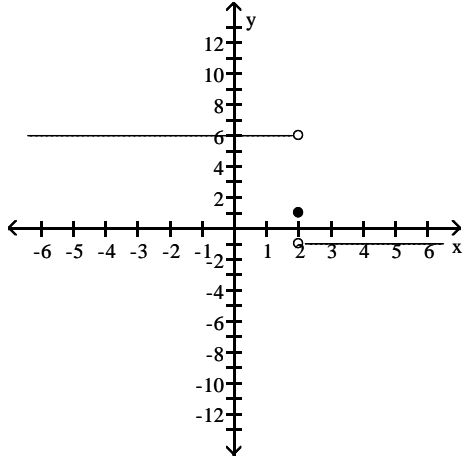

- A) -1; 6
- C) 1; 1

- B) 6; -1
- D) does not exist; does not exist

Answer: B

170) Find $\lim_{x \rightarrow 0} f(x)$

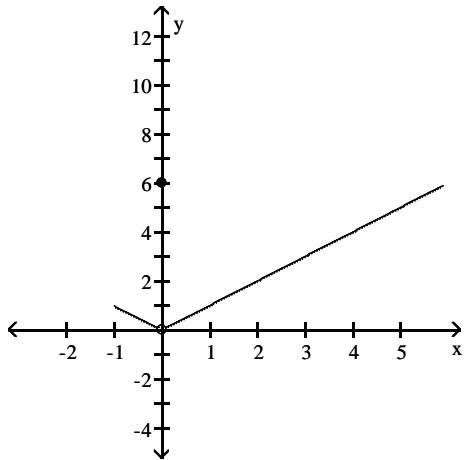

- A) 0

- B) does not exist

- C) -1

- D) 6

Answer: A

Determine the limit by sketching an appropriate graph.

171) $\lim_{x \rightarrow 2^-} f(x)$, where $f(x) = \begin{cases} -5x + 3 & \text{for } x < 2 \\ 2x + 4 & \text{for } x \geq 2 \end{cases}$

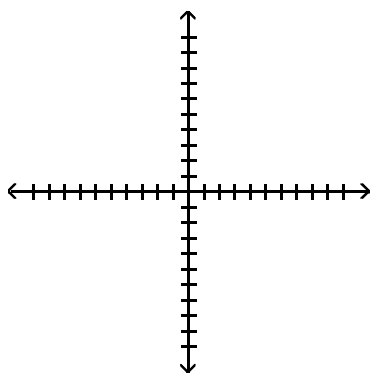

A) -7

B) 5

C) 8

D) 4

Answer: A

172) $\lim_{x \rightarrow 4^+} f(x)$, where $f(x) = \begin{cases} -3x - 5 & \text{for } x < 4 \\ 5x - 4 & \text{for } x \geq 4 \end{cases}$

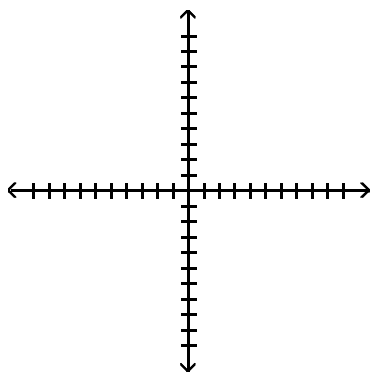

A) -17

B) -3

C) -4

D) 16

Answer: D

173) $\lim_{x \rightarrow -4^+} f(x)$, where $f(x) = \begin{cases} x^2 + 6 & \text{for } x \neq -4 \\ 0 & \text{for } x = -4 \end{cases}$

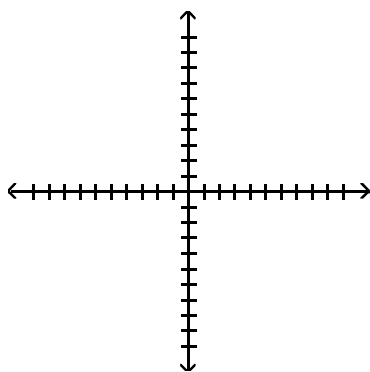

A) 0

B) 22

C) 16

D) 10

Answer: B

174) $\lim_{x \rightarrow 4^-} f(x)$, where $f(x) = \begin{cases} \sqrt{16-x^2} & 0 \leq x < 4 \\ 4 & 4 \leq x < 6 \\ 6 & x = 6 \end{cases}$

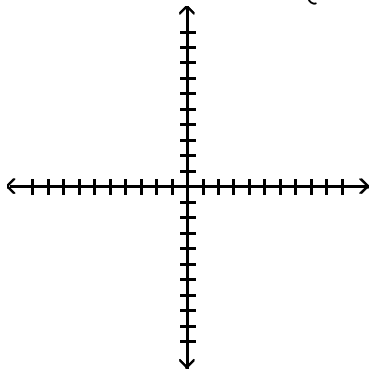

A) 4

B) 6

C) 0

D) Does not exist

Answer: C

175) $\lim_{x \rightarrow -3^+} f(x)$, where $f(x) = \begin{cases} 3x & -3 \leq x < 0, \text{ or } 0 < x \leq 2 \\ 3 & x = 0 \\ 0 & x < -3 \text{ or } x > 2 \end{cases}$

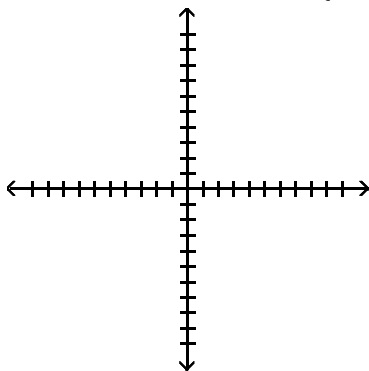

A) 2

B) -0

C) -9

D) Does not exist

Answer: C

Find the limit.

176) $\lim_{x \rightarrow -0.5^-} \sqrt{\frac{x+9}{x+2}}$

A) $\sqrt{\frac{17}{3}}$

B) Does not exist

C) $\frac{17}{3}$

D) $\sqrt{\frac{19}{5}}$

Answer: A

177) $\lim_{x \rightarrow -2^+} \sqrt{\frac{7x^2}{10+x}}$

A) $\sqrt{\frac{7}{2}}$

B) $\sqrt{-\frac{7}{4}}$

C) Does not exist

D) $\frac{7}{2}$

Answer: A

$$178) \lim_{x \rightarrow 2^+} \left(\frac{x}{x+2} \right) \left(\frac{-4x+4}{x^2+2x} \right)$$

A) $-\frac{1}{2}$ B) -1 C) Does not exist D) $-\frac{1}{4}$

Answer: D

$$179) \lim_{h \rightarrow 0^+} \frac{\sqrt{h^2+7h+6} - \sqrt{6}}{h}$$

A) $\frac{7}{2\sqrt{6}}$ B) $\frac{7}{\sqrt{12}}$ C) Does not exist D) $\frac{7}{12}$

Answer: A

$$180) \lim_{h \rightarrow 0^-} \frac{\sqrt{13} - \sqrt{8h^2+9h+13}}{h}$$

A) $\frac{-9}{2\sqrt{13}}$ B) Does not exist C) $\frac{9}{2\sqrt{13}}$ D) $\frac{-9}{\sqrt{26}}$

Answer: A

$$181) \lim_{x \rightarrow -4^+} (x+5) \left(\frac{|x+4|}{x+4} \right)$$

A) 9 B) 1 C) -1 D) Does not exist

Answer: B

$$182) \lim_{x \rightarrow -5^-} (x+3) \left(\frac{|x+5|}{x+5} \right)$$

A) -2 B) 2 C) 8 D) Does not exist

Answer: B

$$183) \lim_{x \rightarrow 3^-} \frac{\sqrt{3x}(x-3)}{|x-3|}$$

A) -3 B) 0 C) Does not exist D) 3

Answer: A

$$184) \lim_{x \rightarrow 3^+} \frac{\sqrt{5x}(x-3)}{|x-3|}$$

A) 0 B) Does not exist C) $-\sqrt{15}$ D) $\sqrt{15}$

Answer: D

Use the graph of the greatest integer function $y = \lfloor x \rfloor$ to find the limit.

$$185) \lim_{x \rightarrow 8^+} \frac{\lfloor x \rfloor}{x}$$

A) 0 B) 1 C) -8 D) 8

Answer: B

186) $\lim_{x \rightarrow 8^+} (x - \lfloor x \rfloor)$

A) 0

B) -16

C) 8

D) 16

Answer: A

Find the limit using $\lim_{x \rightarrow 0} \frac{\sin x}{x} = 1$.

187) $\lim_{x \rightarrow 0} \frac{\sin 5x}{x}$

A) $\frac{1}{5}$

B) 5

C) 1

D) does not exist

Answer: B

188) $\lim_{x \rightarrow 0} \frac{x}{\sin 3x}$

A) $\frac{1}{3}$

B) 3

C) 1

D) does not exist

Answer: A

189) $\lim_{x \rightarrow 0} \frac{\tan 4x}{x}$

A) 1

B) does not exist

C) $\frac{1}{4}$

D) 4

Answer: D

190) $\lim_{x \rightarrow 0} \frac{\sin 5x}{\sin 4x}$

A) 0

B) $\frac{5}{4}$

C) $\frac{4}{5}$

D) does not exist

Answer: B

191) $\lim_{x \rightarrow 0} \frac{\sin 4x}{\sin 5x}$

A) $\frac{5}{4}$

B) 0

C) $\frac{4}{5}$

D) does not exist

Answer: C

192) $\lim_{x \rightarrow 0} \frac{\sin x \cos 4x}{x + x \cos 5x}$

A) $\frac{1}{2}$

B) does not exist

C) $\frac{4}{5}$

D) 0

Answer: A

193) $\lim_{x \rightarrow 0} 6x^2(\cot 3x)(\csc 2x)$

A) does not exist

B) 1

C) $\frac{1}{3}$

D) $\frac{1}{2}$

Answer: B

194) $\lim_{x \rightarrow 0} \frac{x^2 - 2x + \sin x}{x}$

A) 0

B) -1

C) 1

D) does not exist

Answer: B

195) $\lim_{x \rightarrow 0} \frac{\sin(\sin x)}{\sin x}$

A) -1

B) 1

C) does not exist

D) 0

Answer: B

196) $\lim_{x \rightarrow 0} \frac{\sin 3x \cot 4x}{\cot 5x}$

A) does not exist

B) $\frac{12}{5}$

C) 0

D) $\frac{15}{4}$

Answer: C

Provide an appropriate response.

197) Given $\lim_{x \rightarrow 0^-} f(x) = L_L$, $\lim_{x \rightarrow 0^+} f(x) = L_R$, and $L_L \neq L_R$, which of the following statements is true?

I. $\lim_{x \rightarrow 0} f(x) = L_L$

II. $\lim_{x \rightarrow 0} f(x) = L_R$

III. $\lim_{x \rightarrow 0} f(x)$ does not exist.

A) I

B) II

C) none

D) III

Answer: D

198) Given $\lim_{x \rightarrow 0^-} f(x) = L_L$, $\lim_{x \rightarrow 0^+} f(x) = L_R$, and $L_L = L_R$, which of the following statements is false?

I. $\lim_{x \rightarrow 0} f(x) = L_L$

II. $\lim_{x \rightarrow 0} f(x) = L_R$

III. $\lim_{x \rightarrow 0} f(x)$ does not exist.

A) none

B) II

C) I

D) III

Answer: D

199) If $\lim_{x \rightarrow 0} f(x) = L$, which of the following expressions are true?

- I. $\lim_{x \rightarrow 0^-} f(x)$ does not exist.
- II. $\lim_{x \rightarrow 0^+} f(x)$ does not exist.
- III. $\lim_{x \rightarrow 0^-} f(x) = L$
- IV. $\lim_{x \rightarrow 0^+} f(x) = L$

- A) II and III only B) I and II only C) III and IV only D) I and IV only

Answer: C

200) If $\lim_{x \rightarrow 0^-} f(x) = 1$ and $f(x)$ is an odd function, which of the following statements are true?

- I. $\lim_{x \rightarrow 0} f(x) = 1$
- II. $\lim_{x \rightarrow 0^+} f(x) = -1$
- III. $\lim_{x \rightarrow 0} f(x)$ does not exist.

- A) I and II only B) I, II, and III C) I and III only D) II and III only

Answer: D

201) If $\lim_{x \rightarrow 1^-} f(x) = 1$, $\lim_{x \rightarrow 1^+} f(x) = -1$, and $f(x)$ is an even function, which of the following statements are true?

- I. $\lim_{x \rightarrow -1^-} f(x) = -1$
- II. $\lim_{x \rightarrow -1^+} f(x) = -1$
- III. $\lim_{x \rightarrow -1} f(x)$ does not exist.

- A) I, II, and III B) I and II only C) II and III only D) I and III only

Answer: D

202) Given $\epsilon > 0$, find an interval $I = (1, 1 + \delta)$, $\delta > 0$, such that if x lies in I , then $\sqrt{x-1} < \epsilon$. What limit is being verified and what is its value?

- A) $\lim_{x \rightarrow 0^-} \sqrt{x-1} = 0$ B) $\lim_{x \rightarrow 1^+} \sqrt{x} = 1$ C) $\lim_{x \rightarrow 1^+} \sqrt{x-1} = 0$ D) $\lim_{x \rightarrow 1^-} \sqrt{x-1} = 0$

Answer: C

203) Given $\epsilon > 0$, find an interval $I = (3 - \delta, 3)$, $\delta > 0$, such that if x lies in I , then $\sqrt{3-x} < \epsilon$. What limit is being verified and what is its value?

- A) $\lim_{x \rightarrow 3^-} \sqrt{x} = 3$ B) $\lim_{x \rightarrow 3^+} \sqrt{3-x} = 0$ C) $\lim_{x \rightarrow 3^-} \sqrt{3-x} = 0$ D) $\lim_{x \rightarrow 0^-} \sqrt{3-x} = 0$

Answer: C

Find all points where the function is discontinuous.

204)

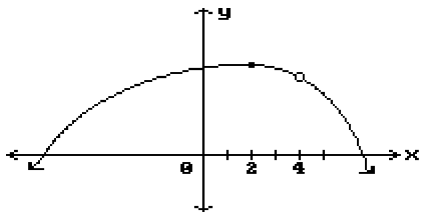

A) $x = 4, x = 2$

B) $x = 2$

C) $x = 4$

D) None

Answer: C

205)

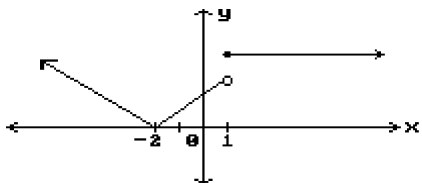

A) $x = 1$

B) $x = -2$

C) $x = -2, x = 1$

D) None

Answer: A

206)

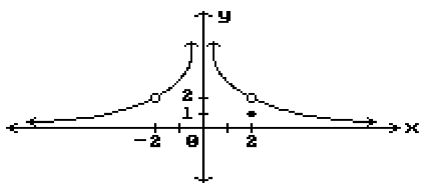

A) $x = 0, x = 2$

B) $x = -2, x = 0, x = 2$

C) $x = -2, x = 0$

D) $x = 2$

Answer: B

207)

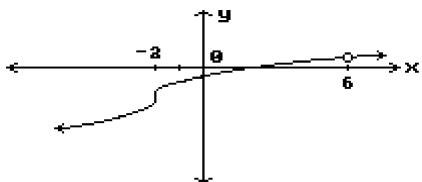

A) None

B) $x = -2, x = 6$

C) $x = -2$

D) $x = 6$

Answer: D

208)

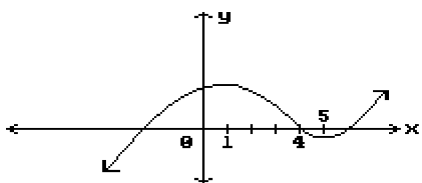

A) $x = 1, x = 5$

B) $x = 4$

C) None

D) $x = 1, x = 4, x = 5$

Answer: C

209)

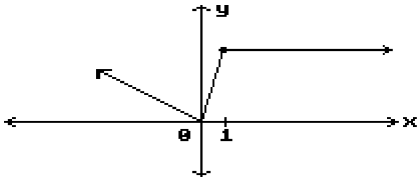

A) $x = 1$

B) None

C) $x = 0$

D) $x = 0, x = 1$

Answer: B

210)

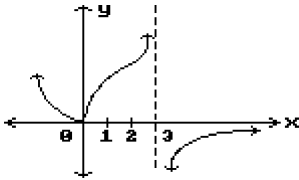

A) $x = 3$

B) $x = 0$

C) None

D) $x = 0, x = 3$

Answer: A

211)

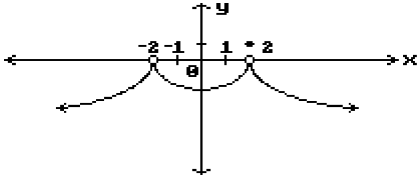

A) $x = 2$

B) $x = -2, x = 2$

C) $x = -2$

D) None

Answer: B

212)

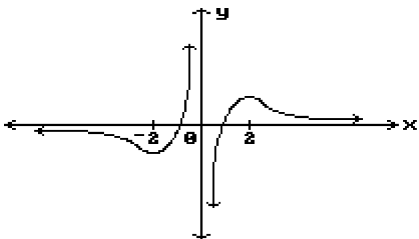

A) $x = -2, x = 2$

B) None

C) $x = -2, x = 0, x = 2$

D) $x = 0$

Answer: D

Answer the question.

213) Does $\lim_{x \rightarrow (-1)^+} f(x)$ exist?

$$f(x) = \begin{cases} -x^2 + 1, & -1 \leq x < 0 \\ 5x, & 0 < x < 1 \\ -3, & x = 1 \\ -5x + 10, & 1 < x < 3 \\ 5, & 3 < x < 5 \end{cases}$$

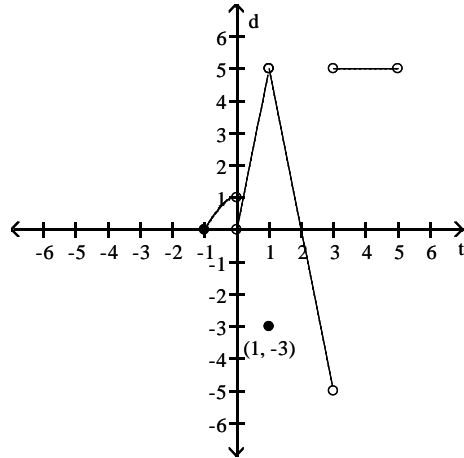

A) Yes

B) No

Answer: A

214) Does $\lim_{x \rightarrow -1^+} f(x) = f(-1)$?

$$f(x) = \begin{cases} -x^2 + 1, & -1 \leq x < 0 \\ 2x, & 0 < x < 1 \\ -4, & x = 1 \\ -2x + 4, & 1 < x < 3 \\ 3, & 3 < x < 5 \end{cases}$$

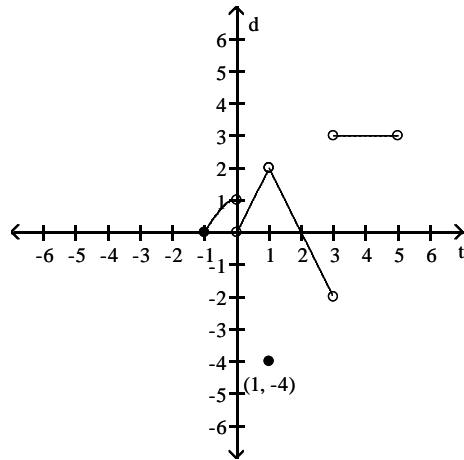

A) No

B) Yes

Answer: B

215) Does $\lim_{x \rightarrow 1} f(x)$ exist?

$$f(x) = \begin{cases} -x^2 + 1, & -1 \leq x < 0 \\ 2x, & 0 < x < 1 \\ -3, & x = 1 \\ -2x + 4, & 1 < x < 3 \\ 4, & 3 < x < 5 \end{cases}$$

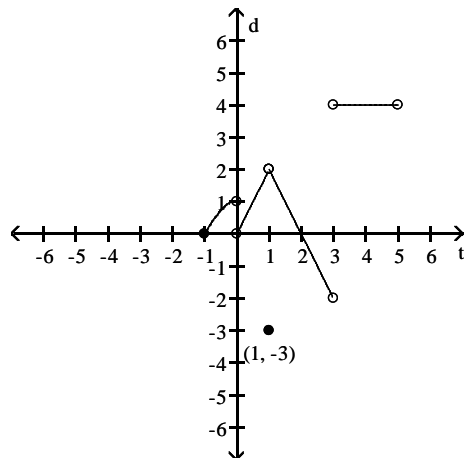

A) No

B) Yes

Answer: B

216) Is f continuous at $f(1)$?

$$f(x) = \begin{cases} -x^2 + 1, & -1 \leq x < 0 \\ 3x, & 0 < x < 1 \\ -4, & x = 1 \\ -3x + 6, & 1 < x < 3 \\ 5, & 3 < x < 5 \end{cases}$$

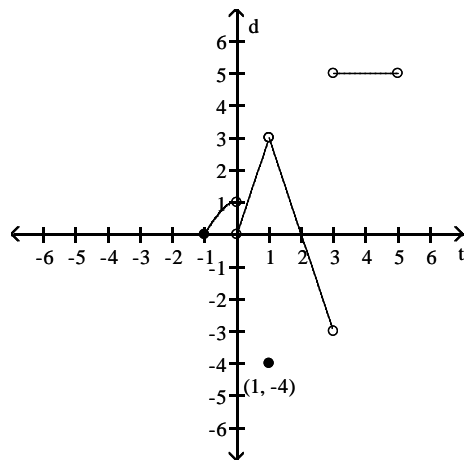

A) Yes

B) No

Answer: B

217) Is f continuous at $f(0)$?

$$f(x) = \begin{cases} -x^2 + 1, & -1 \leq x < 0 \\ 3x, & 0 < x < 1 \\ -5, & x = 1 \\ -3x + 6, & 1 < x < 3 \\ 5, & 3 < x < 5 \end{cases}$$

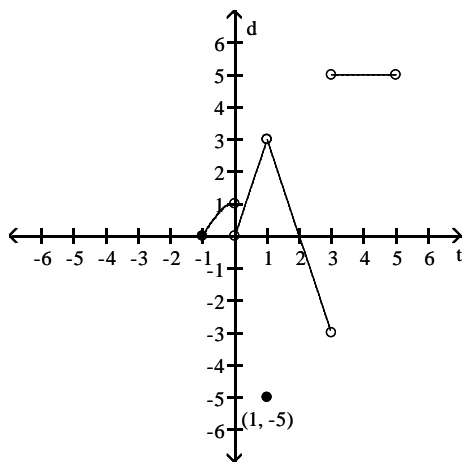

A) No

B) Yes

Answer: A

218) Does $\lim_{x \rightarrow 0} f(x)$ exist?

$$f(x) = \begin{cases} x^3, & -2 < x \leq 0 \\ -2x, & 0 \leq x < 2 \\ 5, & 2 < x \leq 4 \\ 0, & x = 2 \end{cases}$$

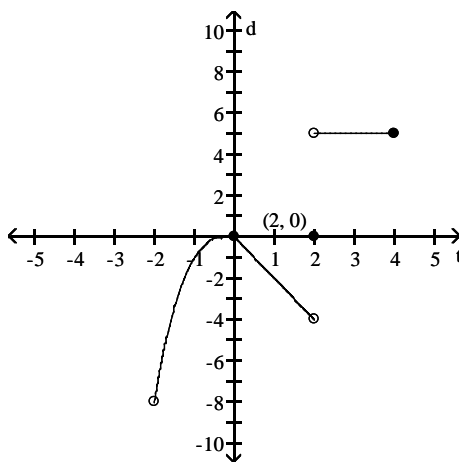

A) No

B) Yes

Answer: B

219) Does $\lim_{x \rightarrow 2} f(x) = f(2)$?

$$f(x) = \begin{cases} x^3, & -2 < x \leq 0 \\ -2x, & 0 \leq x < 2 \\ 6, & 2 < x \leq 4 \\ 0, & x = 2 \end{cases}$$

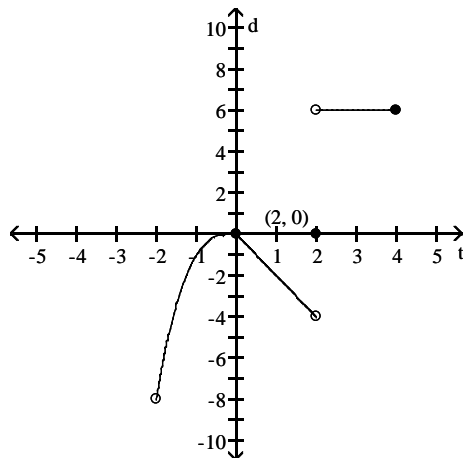

A) No

B) Yes

Answer: A

220) Is f continuous at $x = 0$?

$$f(x) = \begin{cases} x^3, & -2 < x \leq 0 \\ -4x, & 0 \leq x < 2 \\ 5, & 2 < x \leq 4 \\ 0, & x = 2 \end{cases}$$

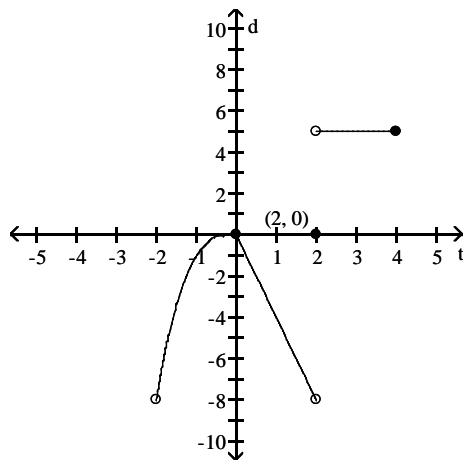

A) No

B) Yes

Answer: B

221) Is f continuous at $x = 4$?

$$f(x) = \begin{cases} x^3, & -2 < x \leq 0 \\ -2x, & 0 \leq x < 2 \\ 2, & 2 < x \leq 4 \\ 0, & x = 2 \end{cases}$$

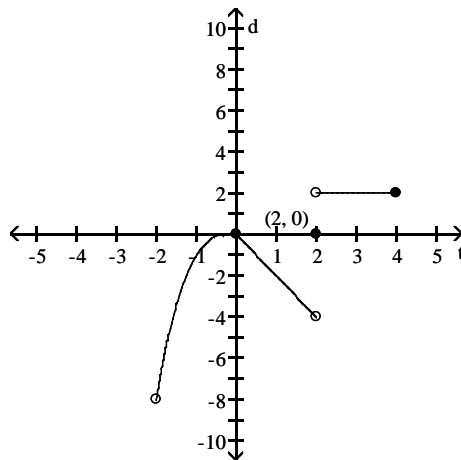

A) No

B) Yes

Answer: B

222) Is f continuous on $(-2, 4]$?

$$f(x) = \begin{cases} x^3, & -2 < x \leq 0 \\ -3x, & 0 \leq x < 2 \\ 5, & 2 < x \leq 4 \\ 0, & x = 2 \end{cases}$$

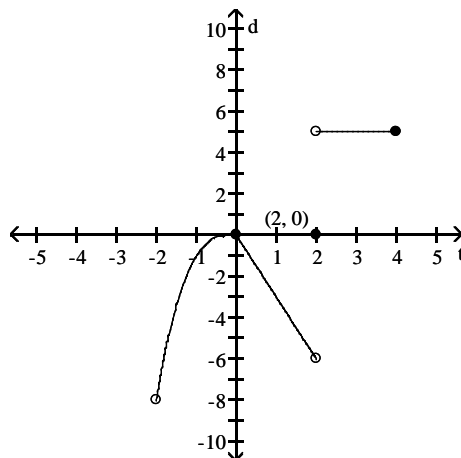

A) Yes

B) No

Answer: B

Solve the problem.

223) To what new value should $f(1)$ be changed to remove the discontinuity?

$$f(x) = \begin{cases} x^2 + 5, & x < 1 \\ 4, & x = 1 \\ x + 5, & x > 1 \end{cases}$$

A) 7

B) 6

C) 5

D) 4

Answer: B

224) To what new value should $f(2)$ be changed to remove the discontinuity?

$$f(x) = \begin{cases} 2x - 1, & x < 2 \\ 5, & x = 2 \\ x + 1, & x > 2 \end{cases}$$

A) 2

B) -5

C) -4

D) 3

Answer: D

Find the intervals on which the function is continuous.

$$225) y = \frac{3}{x+7} - 3x$$

- A) discontinuous only when $x = 7$
 C) discontinuous only when $x = -10$

- B) discontinuous only when $x = -7$
 D) continuous everywhere

Answer: B

$$226) y = \frac{2}{(x+3)^2 + 6}$$

- A) discontinuous only when $x = -24$
 C) discontinuous only when $x = 15$

- B) continuous everywhere
 D) discontinuous only when $x = -3$

Answer: B

$$227) y = \frac{x+5}{x^2 - 7x + 12}$$

- A) discontinuous only when $x = -4$ or $x = 3$
 C) discontinuous only when $x = -3$ or $x = 4$

- B) discontinuous only when $x = 3$
 D) discontinuous only when $x = 3$ or $x = 4$

Answer: D

$$228) y = \frac{2}{x^2 - 25}$$

- A) discontinuous only when $x = -5$ or $x = 5$
 C) discontinuous only when $x = 25$

- B) discontinuous only when $x = -5$
 D) discontinuous only when $x = -25$ or $x = 25$

Answer: A

$$229) y = \frac{5}{|x|+2} - \frac{x^2}{7}$$

- A) continuous everywhere
 C) discontinuous only when $x = -9$

- B) discontinuous only when $x = -7$ or $x = -2$
 D) discontinuous only when $x = -2$

Answer: A

$$230) y = \frac{\sin(3\theta)}{5\theta}$$

- A) discontinuous only when $\theta = \frac{\pi}{2}$
 C) continuous everywhere

- B) discontinuous only when $\theta = \pi$
 D) discontinuous only when $\theta = 0$

Answer: D

$$231) y = \frac{4 \cos \theta}{\theta + 7}$$

- A) discontinuous only when $\theta = \frac{\pi}{2}$
 C) discontinuous only when $\theta = -7$

- B) continuous everywhere
 D) discontinuous only when $\theta = 7$

Answer: C

232) $y = \sqrt{8x + 8}$

- A) continuous on the interval $[-1, \infty)$
 C) continuous on the interval $[1, \infty)$

- B) continuous on the interval $(-1, \infty)$
 D) continuous on the interval $(-\infty, -1]$

Answer: A

233) $y = \sqrt[4]{2x - 4}$

- A) continuous on the interval $(-\infty, 2]$
 C) continuous on the interval $[2, \infty)$

- B) continuous on the interval $[-2, \infty)$
 D) continuous on the interval $(2, \infty)$

Answer: C

234) $y = \sqrt{x^2 - 10}$

- A) continuous everywhere
 B) continuous on the interval $[-\sqrt{10}, \sqrt{10}]$
 C) continuous on the interval $[\sqrt{10}, \infty)$
 D) continuous on the intervals $(-\infty, -\sqrt{10}]$ and $[\sqrt{10}, \infty)$

Answer: D

Find the limit and determine if the function is continuous at the point being approached.

235) $\lim_{x \rightarrow 3\pi} \sin(2x - \sin 2x)$

- A) 0; no B) does not exist; no C) 0; yes D) does not exist; yes

Answer: C

236) $\lim_{x \rightarrow \pi/2} \cos(3x - \cos 3x)$

- A) 0; yes B) does not exist; yes C) 0; no D) does not exist; no

Answer: A

237) $\lim_{x \rightarrow 2\pi} \sin\left(\frac{9\pi}{2} \cos(\tan x)\right)$

- A) does not exist; no B) does not exist; yes C) 1; yes D) 1; no

Answer: C

238) $\lim_{x \rightarrow -\pi/2} \cos\left(\frac{5\pi}{2} \cos(\tan x)\right)$

- A) 1; yes B) does not exist; no C) 1; no D) does not exist; yes

Answer: B

239) $\lim_{x \rightarrow 10} \sec(x \sec^2 x - x \tan^2 x - 1)$

- A) $\sec 9$; yes B) does not exist; no C) $\csc 9$; yes D) $\sec 9$; no

Answer: A

240) $\lim_{x \rightarrow 4} \sin(x \sin^2 x + x \cos^2 x + 3)$

- A) $\sin -1$; yes B) does not exist; no C) $\sin 7$; no D) $\sin 7$; yes

Answer: D

241) $\lim_{\theta \rightarrow -2\pi} \tan(\pi \cos(\sin \theta))$

A) 0; no

B) 1; yes

C) does not exist; no

D) 0; yes

Answer: D

242) $\lim_{\theta \rightarrow 0} \tan(\sin(\theta \cos(\sin \theta)))$

A) 0; no

B) 1; yes

C) does not exist; no

D) 0; yes

Answer: D

243) $\lim_{x \rightarrow 1} \cos\left(\frac{2\pi}{3} \ln(e^x)\right)$

A) does not exist; no

B) 1; yes

C) $-\frac{1}{2}$; no

D) $-\frac{1}{2}$; yes

Answer: D

244) $\lim_{x \rightarrow 0} \sin^{-1}(e^{x^5})$

A) $\frac{\pi}{2}$; yes

B) $\frac{\pi}{4}$; no

C) does not exist; no

D) $\frac{\pi}{4}$; yes

Answer: A

Determine if the given function can be extended to a continuous function at $x = 0$. If so, approximate the extended function's value at $x = 0$ (rounded to four decimal places if necessary). If not, determine whether the function can be continuously extended from the left or from the right and provide the values of the extended functions at $x = 0$. Otherwise write "no continuous extension."

245) $f(x) = \frac{10^{2x} - 1}{x}$

A) No continuous extension

C) $f(0) = 0$ only from the left

B) $f(0) = 0$

D) $f(0) = 0$ only from the right

Answer: B

246) $f(x) = \frac{\cos 2x}{|2x|}$

A) $f(0) = 2$

C) $f(0) = 2$ only from the left

B) No continuous extension

D) $f(0) = 2$ only from the right

Answer: B

247) $f(x) = (1 + 2x)^{1/x}$

A) $f(0) = 2.7183$

C) No continuous extension

B) $f(0) = 5.4366$

D) $f(0) = 7.3891$

Answer: D

248) $f(x) = \frac{\tan x}{x}$

A) $f(0) = 1$

C) $f(0) = 1$ only from the left

B) $f(0) = 1$ only from the right

D) No continuous extension

Answer: A

Find numbers a and b, or k, so that f is continuous at every point.

249)

$$f(x) = \begin{cases} 1, & x < 2 \\ ax + b, & 2 \leq x \leq 3 \\ -1, & x > 3 \end{cases}$$

A) $a = -2, b = -7$

B) $a = 1, b = -1$

C) $a = -2, b = 5$

D) Impossible

Answer: C

250)

$$f(x) = \begin{cases} x^2, & x < -4 \\ ax + b, & -4 \leq x \leq 2 \\ x + 2, & x > 2 \end{cases}$$

A) $a = -2, b = -8$

B) $a = -2, b = 8$

C) $a = 2, b = 8$

D) Impossible

Answer: B

251)

$$f(x) = \begin{cases} 10x + 8, & \text{if } x < -7 \\ kx + 2, & \text{if } x \geq -7 \end{cases}$$

A) $k = \frac{2}{7}$

B) $k = \frac{64}{7}$

C) $k = 16$

D) $k = -\frac{2}{7}$

Answer: B

252)

$$f(x) = \begin{cases} x^2, & \text{if } x \leq 6 \\ x + k, & \text{if } x > 6 \end{cases}$$

A) $k = -6$

B) $k = 30$

C) $k = 42$

D) Impossible

Answer: B

253)

$$f(x) = \begin{cases} x^2, & \text{if } x \leq 4 \\ kx, & \text{if } x > 4 \end{cases}$$

A) $k = \frac{1}{4}$

B) $k = 4$

C) $k = 16$

D) Impossible

Answer: B

SHORT ANSWER. Write the word or phrase that best completes each statement or answers the question.

Provide an appropriate response.

254) Use the Intermediate Value Theorem to prove that $3x^3 + 9x^2 - 3x + 5 = 0$ has a solution between -4 and -3 .

Answer: Let $f(x) = 3x^3 + 9x^2 - 3x + 5$ and let $y_0 = 0$. $f(-4) = -31$ and $f(-3) = 14$. Since f is continuous on $[-4, -3]$ and since $y_0 = 0$ is between $f(-4)$ and $f(-3)$, by the Intermediate Value Theorem, there exists a c in the interval $(-4, -3)$ with the property that $f(c) = 0$. Such a c is a solution to the equation $3x^3 + 9x^2 - 3x + 5 = 0$.

255) Use the Intermediate Value Theorem to prove that $5x^4 - 5x^3 + 3x - 10 = 0$ has a solution between -2 and -1 .

Answer: Let $f(x) = 5x^4 - 5x^3 + 3x - 10$ and let $y_0 = 0$. $f(-2) = 104$ and $f(-1) = -3$. Since f is continuous on $[-2, -1]$ and since $y_0 = 0$ is between $f(-2)$ and $f(-1)$, by the Intermediate Value Theorem, there exists a c in the interval $(-2, -1)$ with the property that $f(c) = 0$. Such a c is a solution to the equation $5x^4 - 5x^3 + 3x - 10 = 0$.

256) Use the Intermediate Value Theorem to prove that $x(x - 2)^2 = 2$ has a solution between 1 and 3 .

Answer: Let $f(x) = x(x - 2)^2$ and let $y_0 = 2$. $f(1) = 1$ and $f(3) = 3$. Since f is continuous on $[1, 3]$ and since $y_0 = 2$ is between $f(1)$ and $f(3)$, by the Intermediate Value Theorem, there exists a c in the interval $(1, 3)$ with the property that $f(c) = 2$. Such a c is a solution to the equation $x(x - 2)^2 = 2$.

257) Use the Intermediate Value Theorem to prove that $7 \sin x = x$ has a solution between $\frac{\pi}{2}$ and π .

Answer: Let $f(x) = \frac{\sin x}{x}$ and let $y_0 = \frac{1}{7}$. $f\left(\frac{\pi}{2}\right) \approx 0.6366$ and $f(\pi) = 0$. Since f is continuous on $\left[\frac{\pi}{2}, \pi\right]$ and since $y_0 = \frac{1}{7}$ is between $f\left(\frac{\pi}{2}\right)$ and $f(\pi)$, by the Intermediate Value Theorem, there exists a c in the interval $\left(\frac{\pi}{2}, \pi\right)$, with the property that $f(c) = \frac{1}{7}$. Such a c is a solution to the equation $7 \sin x = x$.

MULTIPLE CHOICE. Choose the one alternative that best completes the statement or answers the question.

258) Use a calculator to graph the function f to see whether it appears to have a continuous extension to the origin. If it does, use Trace and Zoom to find a good candidate for the extended function's value at $x = 0$. If the function does not appear to have a continuous extension, can it be extended to be continuous at the origin from the right or the left? If so, what do you think the extended function's value(s) should be?

$$f(x) = \frac{6^x - 1}{x}$$

- A) continuous extension exists from the right; $f(0) \approx 1.8145$
- B) continuous extension exists at origin; $f(0) \approx 1.8145$
- C) continuous extension exists from the left; $f(0) \approx 1.8145$
- D) continuous extension exists at origin; $f(0) = 0$

Answer: B

259) Use a calculator to graph the function f to see whether it appears to have a continuous extension to the origin. If it does, use Trace and Zoom to find a good candidate for the extended function's value at $x = 0$. If the function does not appear to have a continuous extension, can it be extended to be continuous at the origin from the right or the left? If so, what do you think the extended function's value(s) should be?

$$f(x) = \frac{4 \sin x}{|x|}$$

- A) continuous extension exists from the right; $f(0) = 1$
continuous extension exists from the left; $f(0) = -1$
- B) continuous extension exists from the right; $f(0) = 4$
continuous extension exists from the left; $f(0) = -4$
- C) continuous extension exists at origin; $f(0) = 4$
- D) continuous extension exists at origin; $f(0) = 0$

Answer: B

SHORT ANSWER. Write the word or phrase that best completes each statement or answers the question.

- 260) A function $y = f(x)$ is continuous on $[-1, 1]$. It is known to be positive at $x = -1$ and negative at $x = 1$. What, if anything, does this indicate about the equation $f(x) = 0$? Illustrate with a sketch.

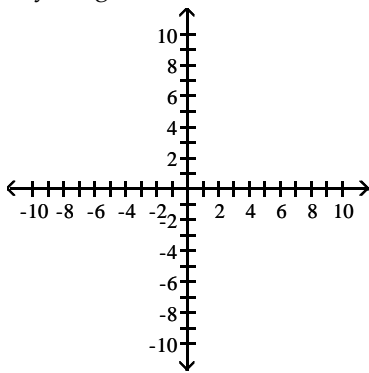

Answer: The Intermediate Value Theorem implies that there is at least one solution to $f(x) = 0$ on the interval $[-1, 1]$.

Possible graph:

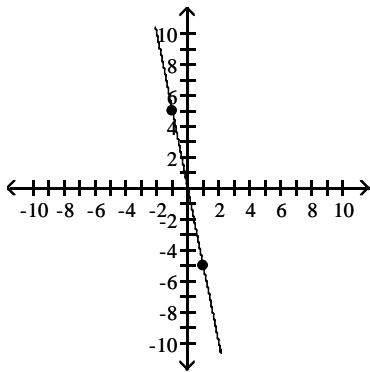

- 261) Explain why the following five statements ask for the same information.

- Find the roots of $f(x) = 4x^3 - 3x - 4$.
- Find the x -coordinate of the points where the curve $y = 4x^3$ crosses the line $y = 3x + 4$.
- Find all the values of x for which $4x^3 - 3x = 4$.
- Find the x -coordinates of the points where the cubic curve $y = 4x^3 - 3x$ crosses the line $y = 4$.
- Solve the equation $4x^3 - 3x - 4 = 0$.

Answer: The roots of $f(x)$ are the solutions to the equation $f(x) = 0$. Statement (b) is asking for the solution to the equation $4x^3 = 3x + 4$. Statement (d) is asking for the solution to the equation $4x^3 - 3x = 4$. These three equations are equivalent to the equations in statements (c) and (e). As five equations are equivalent, their solutions are the same.

- 262) If $f(x) = 2x^3 - 5x + 5$, show that there is at least one value of c for which $f(x)$ equals π .

Answer: Notice that $f(0) = 5$ and $f(1) = 2$. As f is continuous on $[0, 1]$, the Intermediate Value Theorem implies that there is a number c such that $f(c) = \pi$.

263) If functions $f(x)$ and $g(x)$ are continuous for $0 \leq x \leq 6$, could $\frac{f(x)}{g(x)}$ possibly be discontinuous at a point of $[0,6]$?

Provide an example.

Answer: Yes, if $f(x) = 1$ and $g(x) = x - 3$, then $h(x) = \frac{1}{x - 3}$ is discontinuous at $x = 3$.

264) Give an example of a function $f(x)$ that is continuous at all values of x except at $x = 7$, where it has a removable discontinuity. Explain how you know that f is discontinuous at $x = 7$ and how you know the discontinuity is removable.

Answer: Let $f(x) = \frac{\sin(x - 7)}{(x - 7)}$ be defined for all $x \neq 7$. The function f is continuous for all $x \neq 7$. The function is not defined at $x = 7$ because division by zero is undefined; hence f is not continuous at $x = 7$. This discontinuity is removable because $\lim_{x \rightarrow 7} \frac{\sin(x - 7)}{x - 7} = 1$. (We can extend the function to $x = 7$ by defining its value to be 1.)

265) Give an example of a function $f(x)$ that is continuous for all values of x except $x = 10$, where it has a nonremovable discontinuity. Explain how you know that f is discontinuous at $x = 10$ and why the discontinuity is nonremovable.

Answer: Let $f(x) = \frac{1}{(x - 10)^2}$, for all $x \neq 10$. The function f is continuous for all $x \neq 10$, and $\lim_{x \rightarrow 10} \frac{1}{(x - 10)^2} = \infty$. As f is unbounded as x approaches 10, f is discontinuous at $x = 10$, and, moreover, this discontinuity is nonremovable.

MULTIPLE CHOICE. Choose the one alternative that best completes the statement or answers the question.

For the function f whose graph is given, determine the limit.

266) Find $\lim_{x \rightarrow -1^-} f(x)$ and $\lim_{x \rightarrow -1^+} f(x)$.

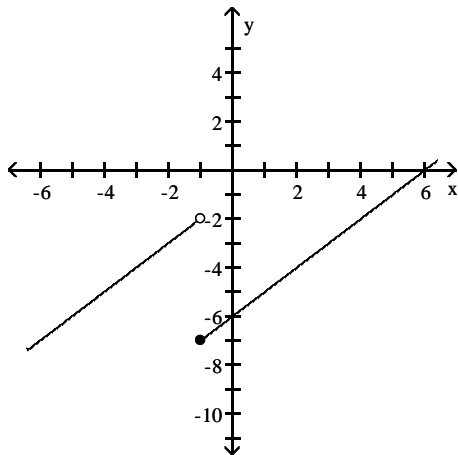

A) -5; -2

B) -7; -2

C) -7; -5

D) -2; -7

Answer: D

267) Find $\lim_{x \rightarrow 2^-} f(x)$ and $\lim_{x \rightarrow 2^+} f(x)$.

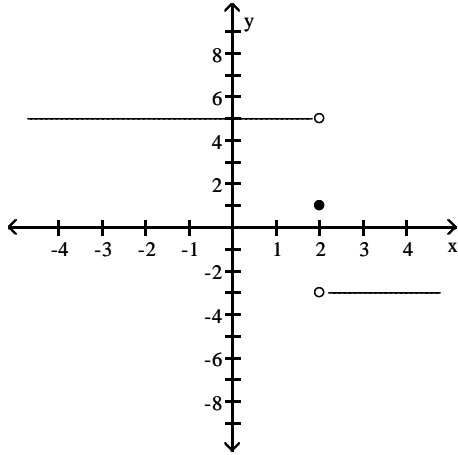

- A) 5; -3
 - C) 1; 1
- Answer: A

- B) does not exist; does not exist
- D) -3; 5

268) Find $\lim_{x \rightarrow 2^+} f(x)$.

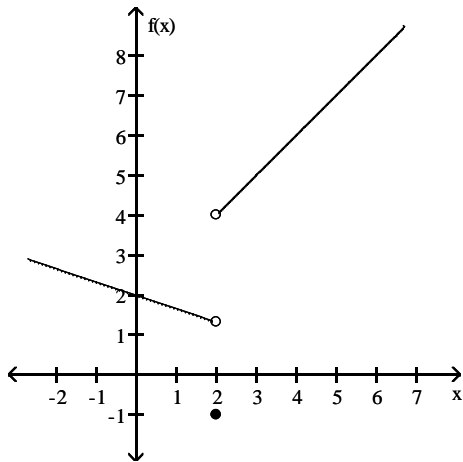

- A) 4
- Answer: A

B) -1

C) 5

D) 1.3

269) Find $\lim_{x \rightarrow 1^-} f(x)$.

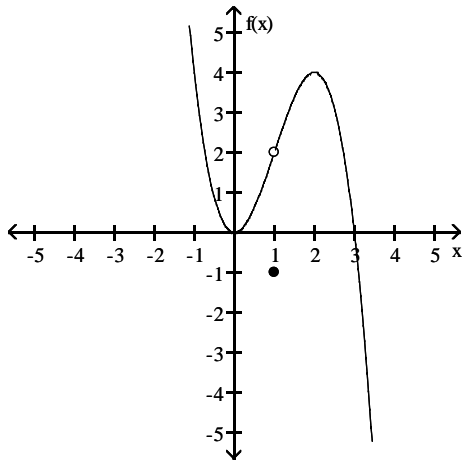

A) 2

B) -1

C) $\frac{1}{2}$

D) does not exist

Answer: A

270) Find $\lim_{x \rightarrow 1^+} f(x)$.

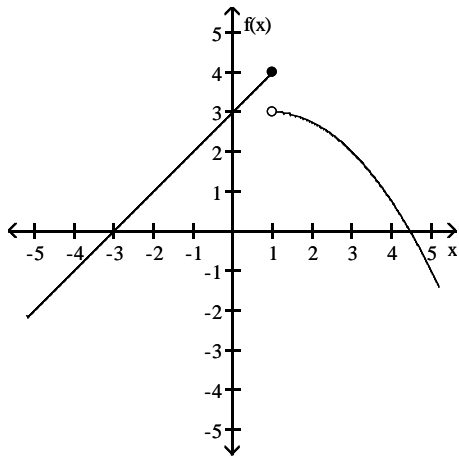

A) 3

B) does not exist

C) $3\frac{1}{2}$

D) 4

Answer: A

271) Find $\lim_{x \rightarrow 0} f(x)$.

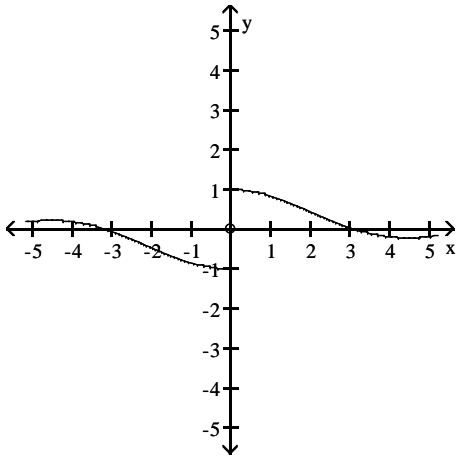

A) 0

B) does not exist

C) -1

D) 1

Answer: B

272) Find $\lim_{x \rightarrow 0} f(x)$.

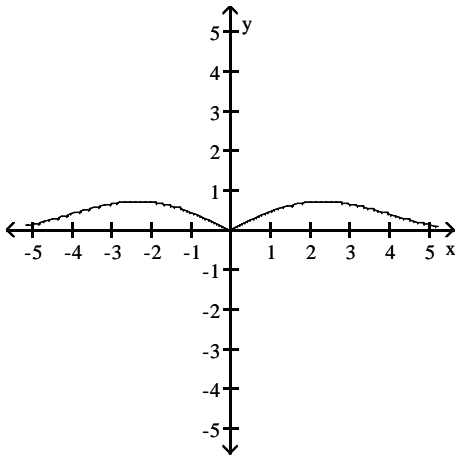

A) 1

B) -1

C) does not exist

D) 0

Answer: D

273) Find $\lim_{x \rightarrow 0} f(x)$.

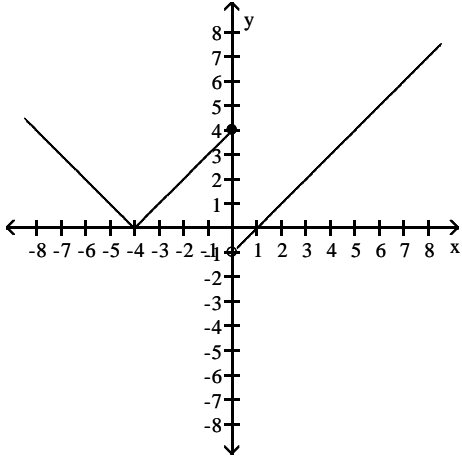

A) does not exist

B) 4

C) 0

D) -4

Answer: A

274) Find $\lim_{x \rightarrow -1} f(x)$.

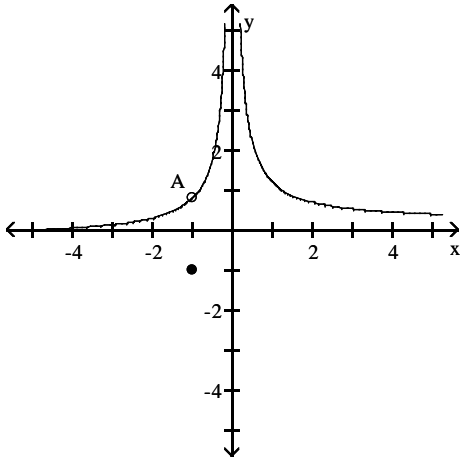

A) does not exist

B) -1

C) $-\frac{4}{5}$

D) $\frac{4}{5}$

Answer: D

275) Find $\lim_{x \rightarrow \infty} f(x)$.

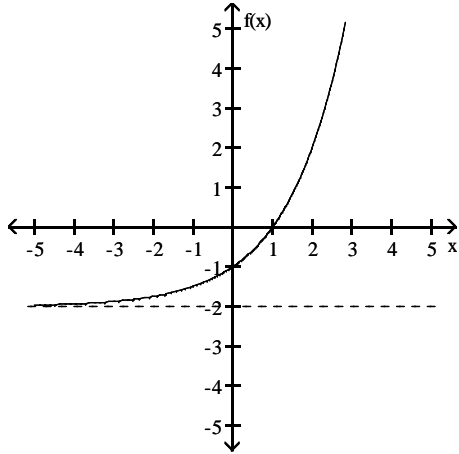

A) -2

B) 0

C) does not exist

D) ∞

Answer: D

Find the limit.

276) $\lim_{x \rightarrow \infty} \frac{5}{x} - 2$

A) -2

B) 2

C) 3

D) -7

Answer: A

277) $\lim_{x \rightarrow \infty} \frac{6}{5 - (6/x^2)}$

A) 6

B) $-\infty$

C) $\frac{6}{5}$

D) -6

Answer: C

278) $\lim_{x \rightarrow \infty} \frac{-1 + (6/x)}{5 - (1/x^2)}$

A) ∞

B) $-\frac{1}{5}$

C) $-\infty$

D) $\frac{1}{5}$

Answer: B

279) $\lim_{x \rightarrow \infty} \frac{x^2 - 6x + 11}{x^3 + 8x^2 + 18}$

A) $\frac{11}{18}$

B) ∞

C) 0

D) 1

Answer: C

280) $\lim_{x \rightarrow -\infty} \frac{-7x^2 - 9x + 2}{-13x^2 - 8x + 3}$

A) ∞

B) $\frac{7}{13}$

C) 1

D) $\frac{2}{3}$

Answer: B

$$281) \lim_{x \rightarrow \infty} \frac{5x + 1}{16x - 7}$$

A) $\frac{5}{16}$

B) $-\frac{1}{7}$

C) 0

D) ∞

Answer: A

$$282) \lim_{x \rightarrow \infty} \frac{8x^3 - 2x^2 + 3x}{-x^3 - 2x + 6}$$

A) -8

B) $\frac{3}{2}$

C) 8

D) ∞

Answer: A

$$283) \lim_{x \rightarrow -\infty} \frac{4x^3 + 3x^2}{x - 6x^2}$$

A) $-\frac{1}{2}$

B) 4

C) $-\infty$

D) ∞

Answer: D

$$284) \lim_{x \rightarrow \infty} \frac{\cos 5x}{x}$$

A) $-\infty$

B) 5

C) 1

D) 0

Answer: D

Divide numerator and denominator by the highest power of x in the denominator to find the limit.

$$285) \lim_{x \rightarrow \infty} \sqrt{\frac{16x^2}{3 + 9x^2}}$$

A) does not exist

B) $\frac{16}{3}$

C) $\frac{4}{3}$

D) $\frac{16}{9}$

Answer: C

$$286) \lim_{x \rightarrow \infty} \sqrt{\frac{25x^2 + x - 3}{(x - 11)(x + 1)}}$$

A) ∞

B) 25

C) 0

D) 5

Answer: D

$$287) \lim_{x \rightarrow \infty} \frac{3\sqrt{x} + x - 1}{4x - 2}$$

A) $\frac{1}{4}$

B) $\frac{3}{4}$

C) ∞

D) 0

Answer: D

$$288) \lim_{x \rightarrow \infty} \frac{3x^{-1} - 2x^{-3}}{5x^{-2} + x^{-5}}$$

A) $-\infty$

B) 0

C) $\frac{3}{5}$

D) ∞

Answer: D

$$289) \lim_{x \rightarrow \infty} \frac{\sqrt[3]{x} - 6x - 4}{-7x + x^{2/3} + 4}$$

A) $-\infty$

B) 0

C) $\frac{6}{7}$

D) $\frac{7}{6}$

Answer: C

$$290) \lim_{t \rightarrow \infty} \frac{\sqrt{9t^2 - 27}}{t - 3}$$

A) 27

B) does not exist

C) 9

D) 3

Answer: D

$$291) \lim_{t \rightarrow \infty} \frac{\sqrt{4t^2 - 8}}{t - 2}$$

A) 2

B) does not exist

C) 8

D) 4

Answer: A

$$292) \lim_{x \rightarrow \infty} \frac{5x + 3}{\sqrt{3x^2 + 1}}$$

A) $\frac{5}{\sqrt{3}}$

B) 0

C) $\frac{5}{3}$

D) ∞

Answer: A

Find the limit.

$$293) \lim_{x \rightarrow -2} \frac{1}{x + 2}$$

A) 1/2

B) $-\infty$

C) ∞

D) Does not exist

Answer: D

$$294) \lim_{x \rightarrow 9^-} \frac{1}{x - 9}$$

A) 0

B) ∞

C) $-\infty$

D) -1

Answer: C

$$295) \lim_{x \rightarrow -7^+} \frac{1}{x + 7}$$

A) ∞

B) -1

C) 0

D) $-\infty$

Answer: A

296) $\lim_{x \rightarrow 7^+} \frac{1}{(x-7)^2}$

A) ∞

B) 0

C) $-\infty$

D) -1

Answer: A

297) $\lim_{x \rightarrow -3^-} \frac{1}{x^2 - 9}$

A) $-\infty$

B) -1

C) ∞

D) 0

Answer: C

298) $\lim_{x \rightarrow 5^+} \frac{3}{x^2 - 25}$

A) ∞

B) 0

C) 1

D) $-\infty$

Answer: A

299) $\lim_{x \rightarrow 1^-} \frac{3}{x^2 - 1}$

A) $-\infty$

B) 0

C) 1

D) ∞

Answer: A

300) $\lim_{x \rightarrow 0} \frac{1}{x^{2/3}}$

A) 2/3

B) $-\infty$

C) ∞

D) 0

Answer: C

301) $\lim_{x \rightarrow (\pi/2)^+} \tan x$

A) $-\infty$

B) 1

C) 0

D) ∞

Answer: A

302) $\lim_{x \rightarrow (-\pi/2)^-} \sec x$

A) 1

B) $-\infty$

C) 0

D) ∞

Answer: D

303) $\lim_{x \rightarrow 0^+} (1 + \csc x)$

A) 1

B) ∞

C) 0

D) Does not exist

Answer: B

304) $\lim_{x \rightarrow 0} (1 - \cot x)$

A) $-\infty$

B) 0

C) ∞

D) Does not exist

Answer: D

305) $\lim_{x \rightarrow -1} \frac{x^2}{3} - \frac{1}{x}$
 A) $\frac{1}{3}$

B) $\frac{4}{3}$

C) 0

D) ∞

Answer: B

306) $\lim_{x \rightarrow \sqrt[3]{5}} \frac{x^2}{5} - \frac{1}{x}$

A) 0

B) $2\sqrt[3]{5}$

C) ∞

D) $-\infty$

Answer: A

307) $\lim_{x \rightarrow -1^-} \frac{x^2 - 5x + 4}{x^3 - x}$

A) Does not exist

B) $-\infty$

C) ∞

D) 0

Answer: B

308) $\lim_{x \rightarrow 0} \frac{x^2 - 8x + 15}{x^3 - 9x}$

A) 15

B) ∞

C) $-\infty$

D) Does not exist

Answer: D

309) $\lim_{x \rightarrow 0^+} \left(\frac{1}{x^{1/5}} + 8 \right)$

A) $-\infty$

B) Does not exist

C) ∞

D) 8

Answer: C

310) $\lim_{x \rightarrow 0^-} \left(\frac{1}{x^{1/5}} + 8 \right)$

A) Does not exist

B) ∞

C) 8

D) $-\infty$

Answer: D

311) $\lim_{x \rightarrow 1^+} \left(\frac{1}{x^{4/5}} - \frac{1}{(x-1)^{2/5}} \right)$

A) 0

B) ∞

C) Does not exist

D) $-\infty$

Answer: D

312) $\lim_{x \rightarrow 1^-} \left(\frac{1}{x^{4/5}} - \frac{1}{(x-1)^{3/5}} \right)$

A) 0

B) Does not exist

C) ∞

D) $-\infty$

Answer: C

Graph the rational function. Include the graphs and equations of the asymptotes.

313) $y = \frac{x}{x+1}$

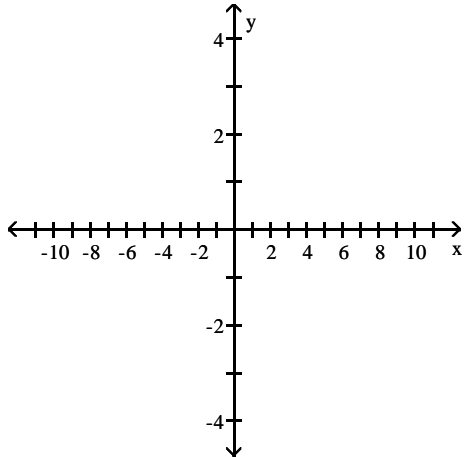

A) asymptotes: $x = -1, y = 1$

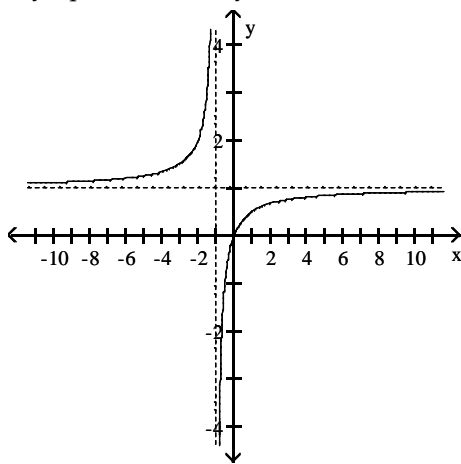

B) asymptotes: $x = 1, y = 1$

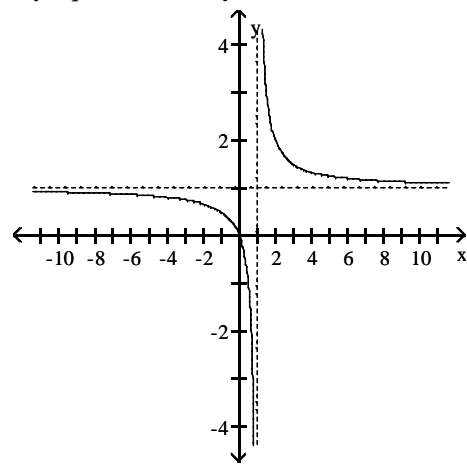

C) asymptotes: $x = 1, y = 0$

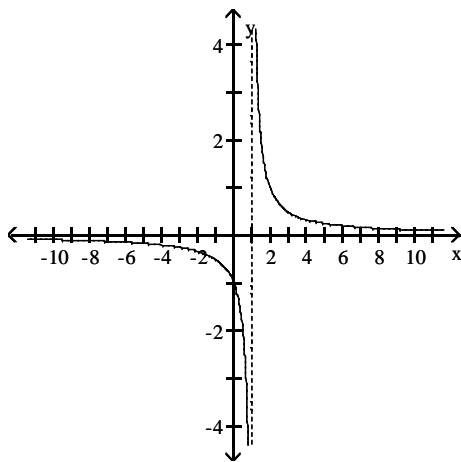

D) asymptotes: $x = -1, y = 0$

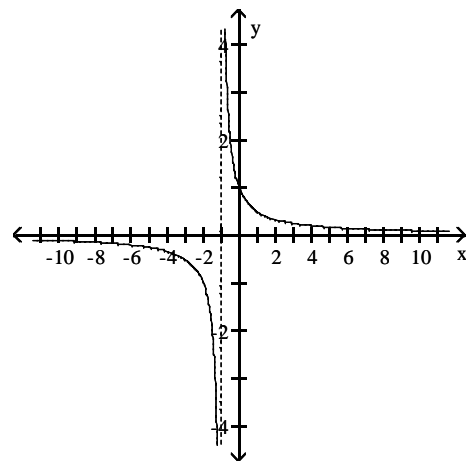

Answer: A

314) $y = \frac{x}{x^2 + x + 4}$

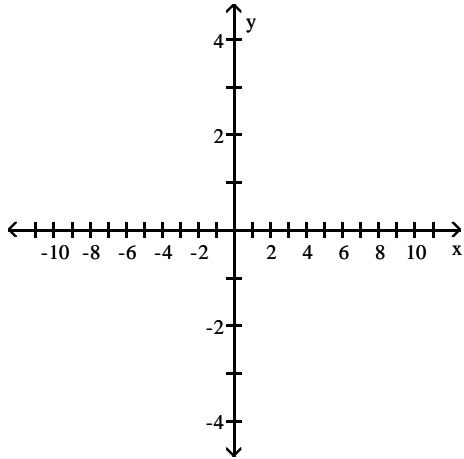

A) asymptote: $y = 0$

B) asymptote: $y = 0$

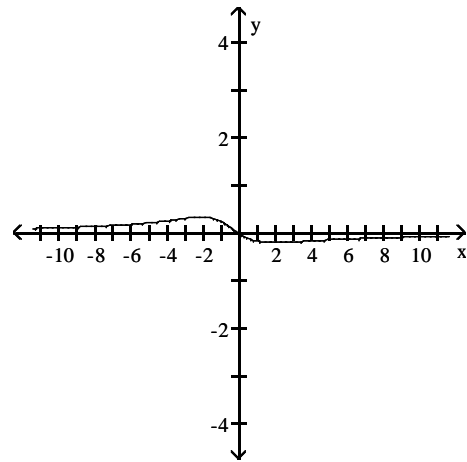
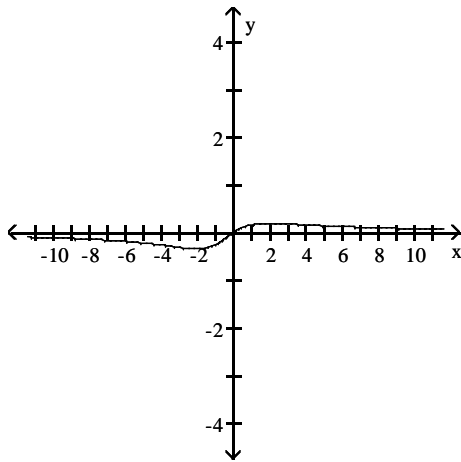

C) asymptote: $y = 1$

D) asymptotes: $x = 4, x = -4$

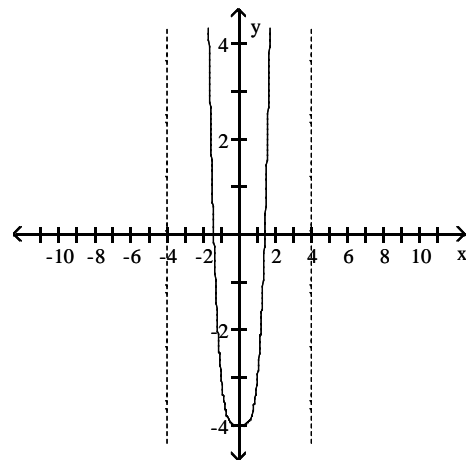
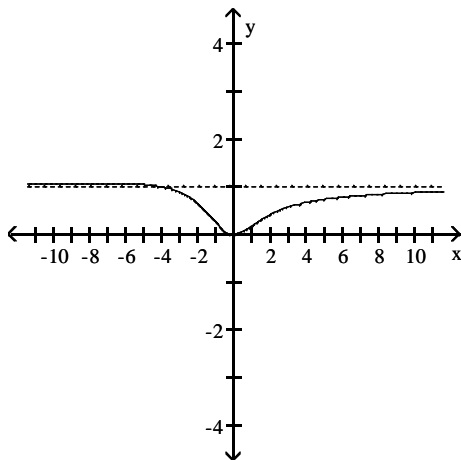

Answer: A

315) $y = \frac{x^2 + 1}{x^3}$

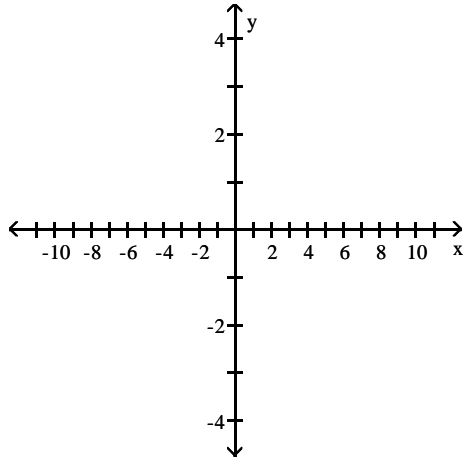

A) asymptotes: $x = 0, y = 0$

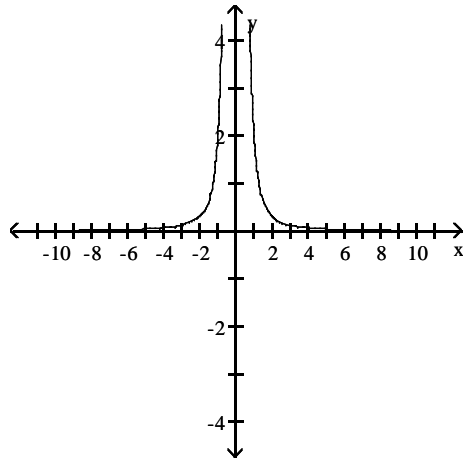

C) asymptote: $y = 0$

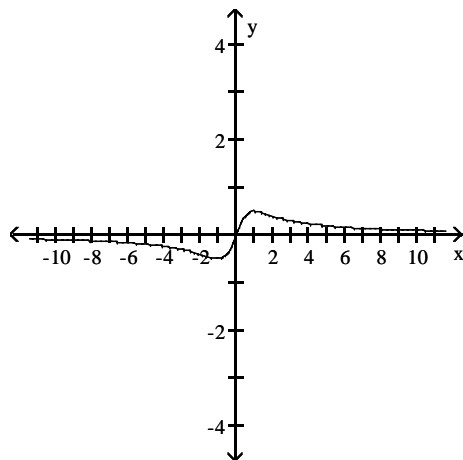

B) asymptotes: $x = 0, y = 0$

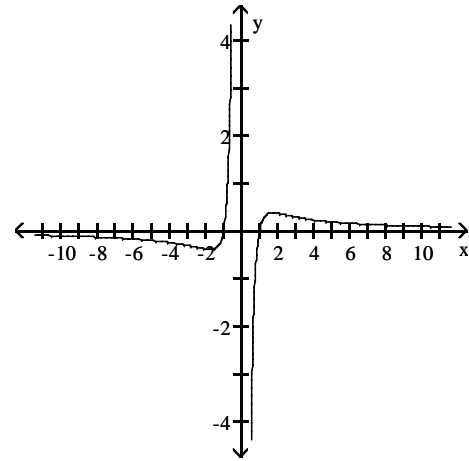

D) asymptotes: $x = 0, y = 0$

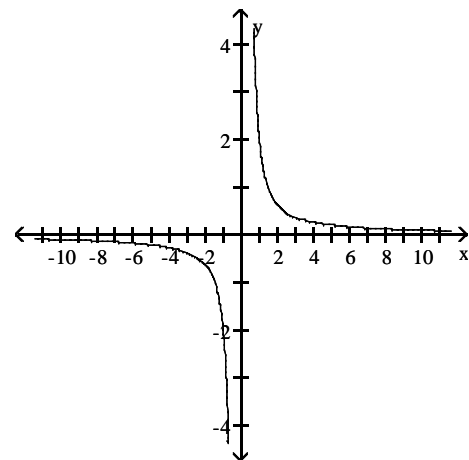

Answer: D

316) $y = \frac{1}{x+1}$

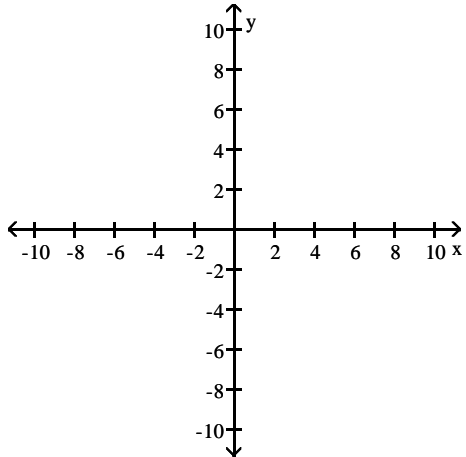

A) asymptotes: $x = 1, y = 0$

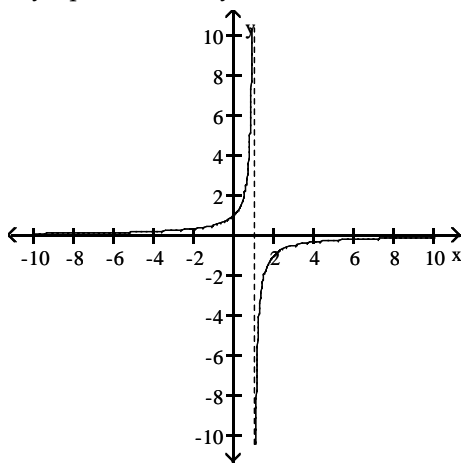

B) asymptotes: $x = -1, y = 0$

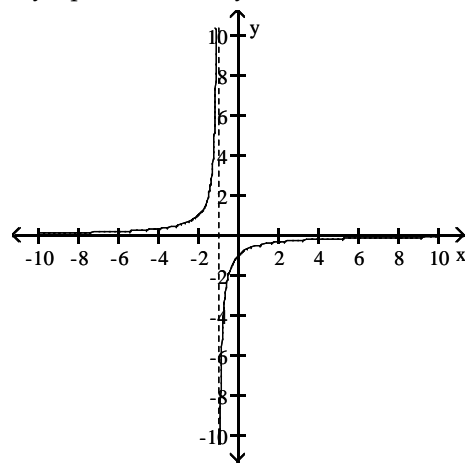

C) asymptotes: $x = -1, y = 0$

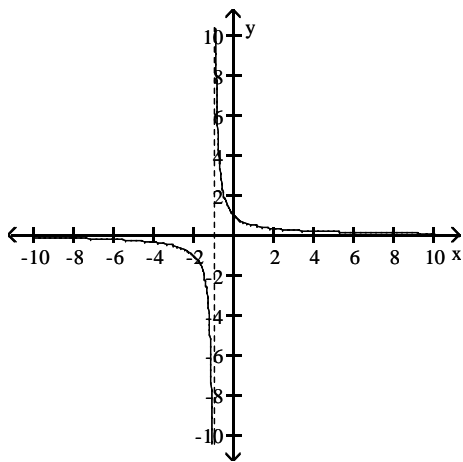

D) asymptotes: $x = 1, y = 0$

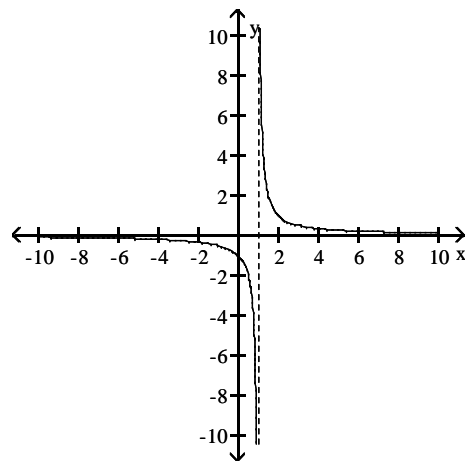

Answer: C

317) $y = \frac{x-1}{x+1}$

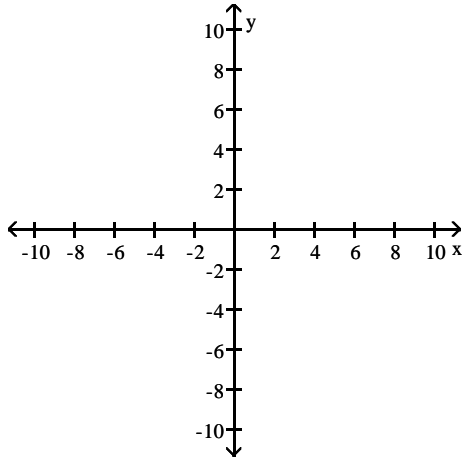

A) asymptotes: $x = -1, y = 1$

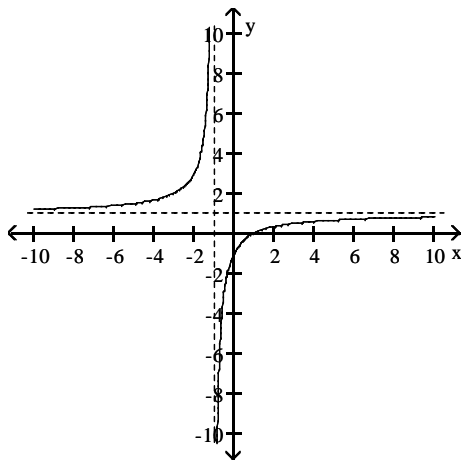

C) asymptotes: $x = -1, y = -1$

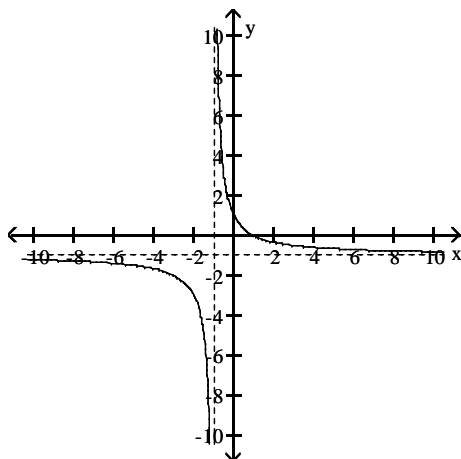

B) asymptotes: $x = 1, y = -1$

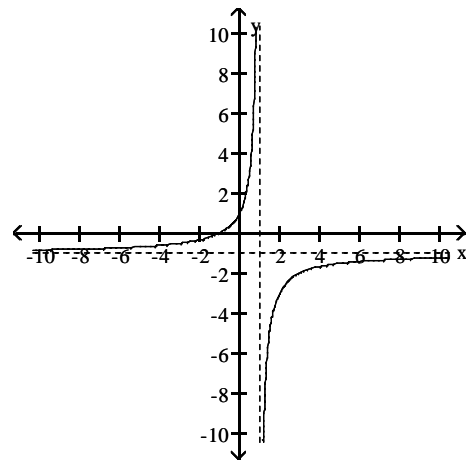

D) asymptotes: $x = 1, y = 1$

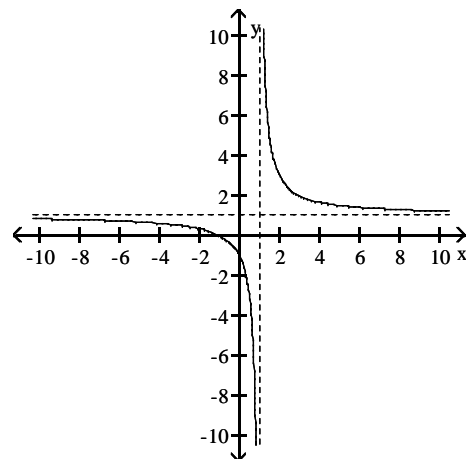

Answer: A

318) $y = \frac{1}{(x+2)^2}$

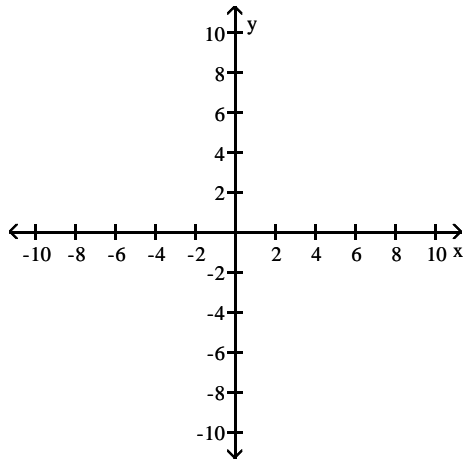

A) asymptotes: $x = 2, y = 0$

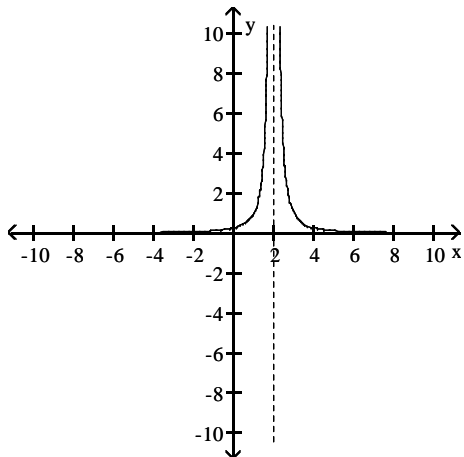

B) asymptotes: $x = 2, y = 0$

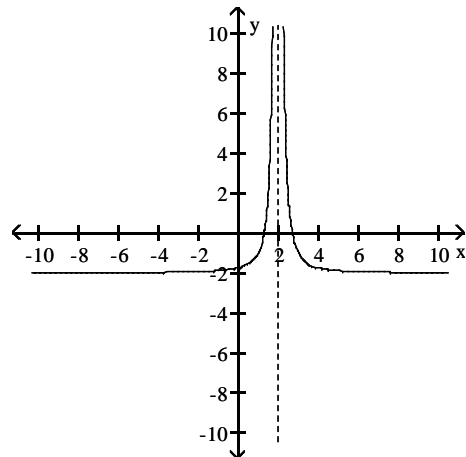

C) asymptotes: $x = -2, y = 0$

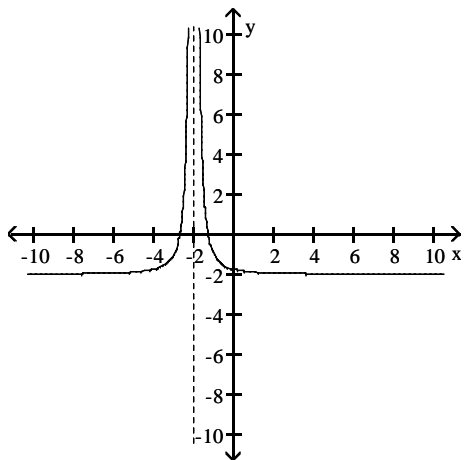

D) asymptotes: $x = -2, y = 0$

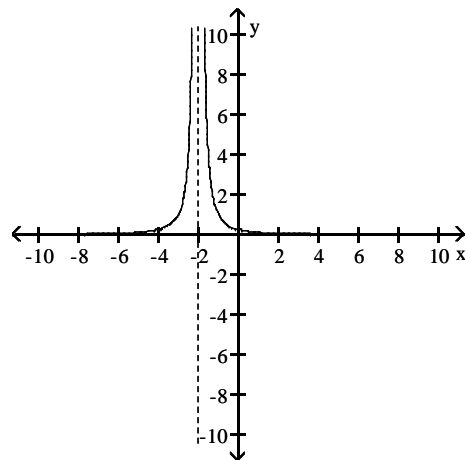

Answer: D

319) $y = \frac{2x^2}{4 - x^2}$

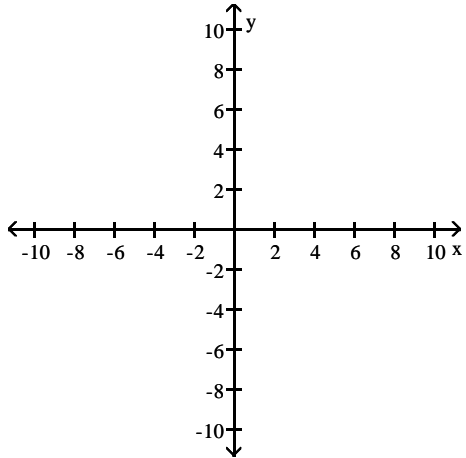

A) asymptotes: $x = -2, x = 2, y = 0$

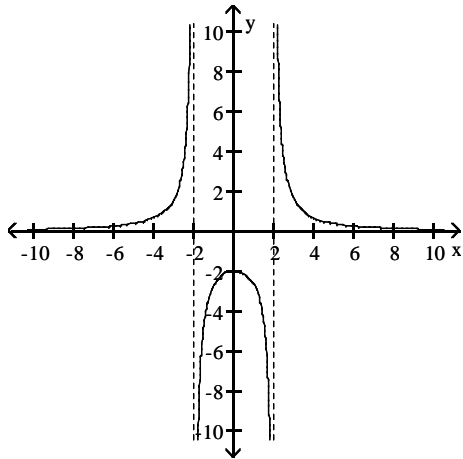

C) asymptotes: $x = -2, x = 2, y = 0$

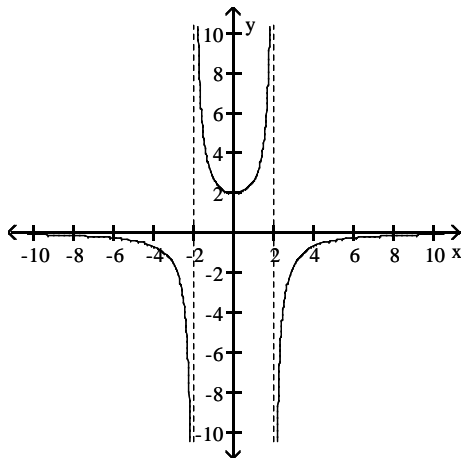

B) asymptotes: $x = -2, x = 2, y = 2$

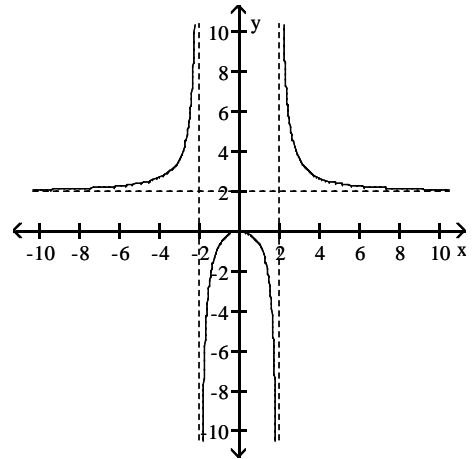

D) asymptotes: $x = -2, x = 2, y = -2$

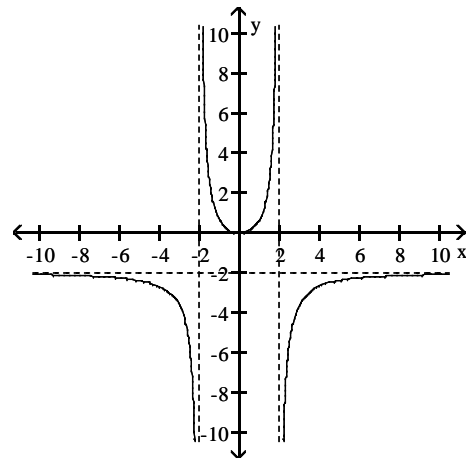

Answer: D

$$320) y = \frac{2 - x^2}{2x + 4}$$

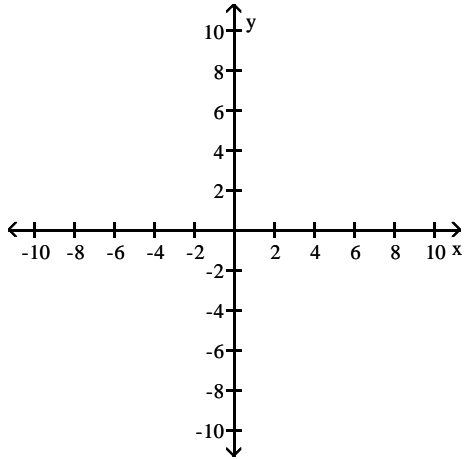

A) asymptotes: $x = -2$, $y = -x + 2$

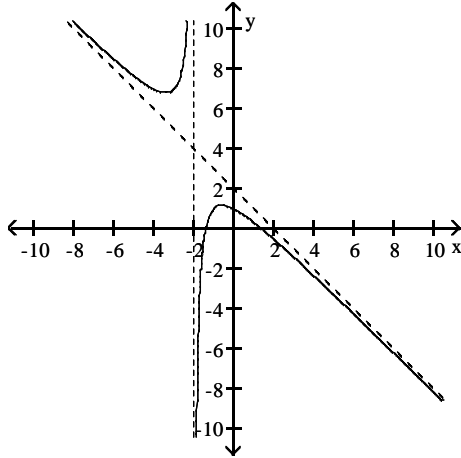

B) asymptotes: $x = -4$, $y = -\frac{1}{8}x + \frac{1}{2}$

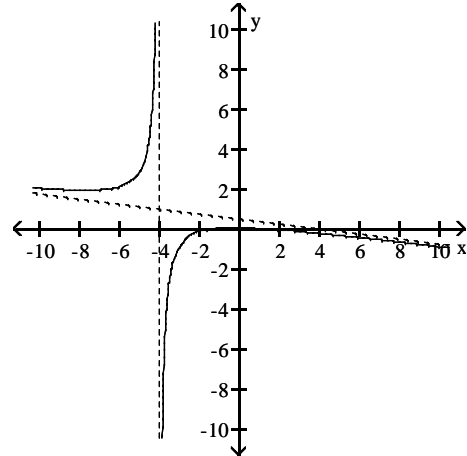

C) asymptotes: $x = -2$, $y = -\frac{1}{4}x + \frac{1}{2}$

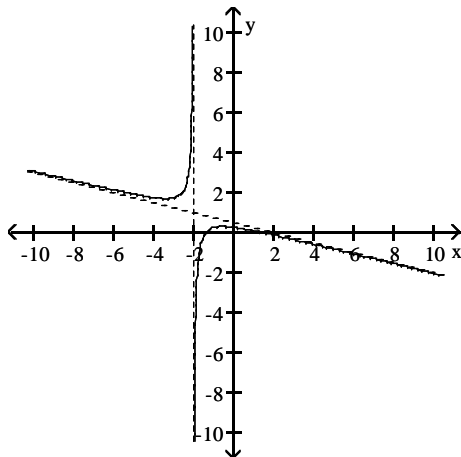

D) asymptotes: $x = -2$, $y = -\frac{1}{2}x + 1$

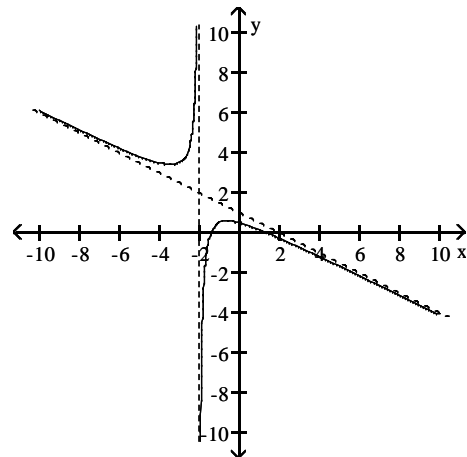

Answer: D

$$321) y = \frac{2 - 2x - x^2}{x}$$

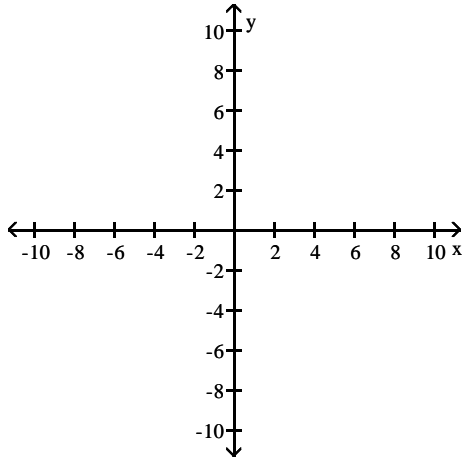

A) asymptotes: $x = 0$, $y = -x - 2$

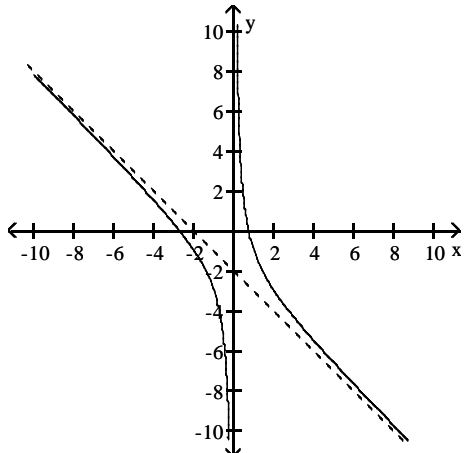

B) asymptotes: $x = 0$, $y = -x - 4$

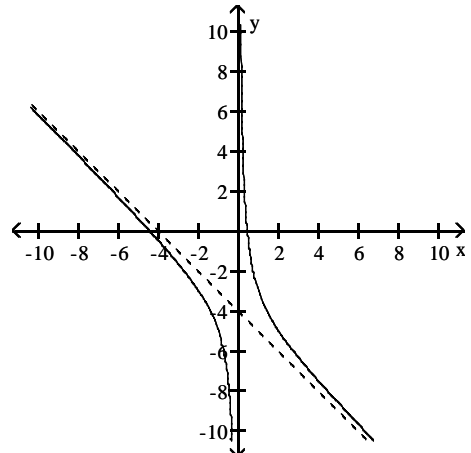

C) asymptotes: $x = 0$, $y = -x + 2$

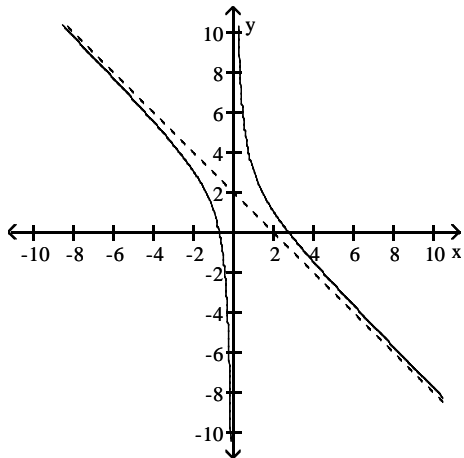

D) asymptotes: $x = 0$, $y = -x$

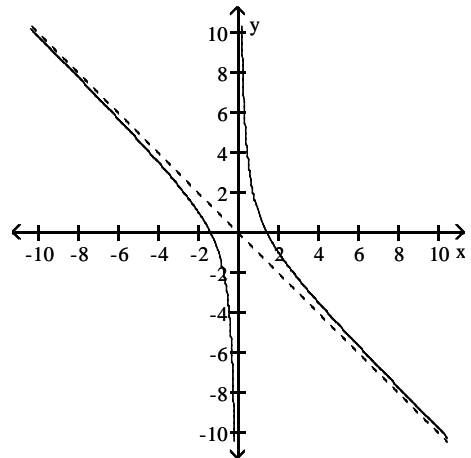

Answer: A

SHORT ANSWER. Write the word or phrase that best completes each statement or answers the question.

Sketch the graph of a function $y = f(x)$ that satisfies the given conditions.

322) $f(0) = 0$, $f(1) = 5$, $f(-1) = -5$, $\lim_{x \rightarrow -\infty} f(x) = -4$, $\lim_{x \rightarrow \infty} f(x) = 4$.

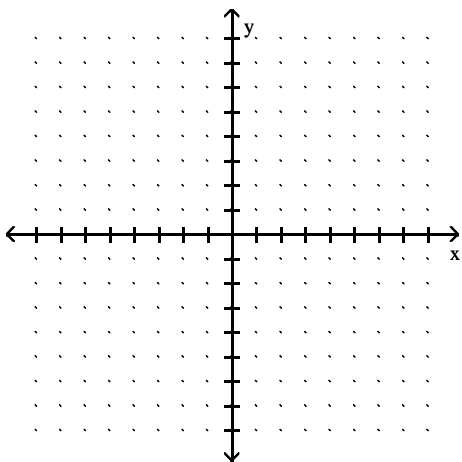

Answer: Answers may vary. One possible answer:

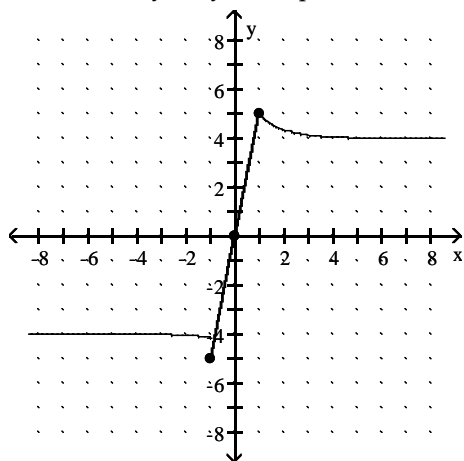

323) $f(0) = 0$, $f(1) = 5$, $f(-1) = 5$, $\lim_{x \rightarrow \pm\infty} f(x) = -5$.

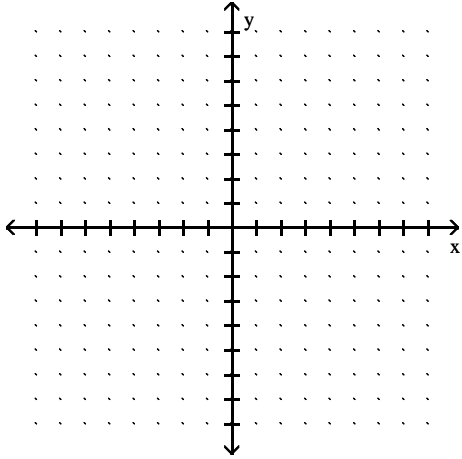

Answer: Answers may vary. One possible answer:

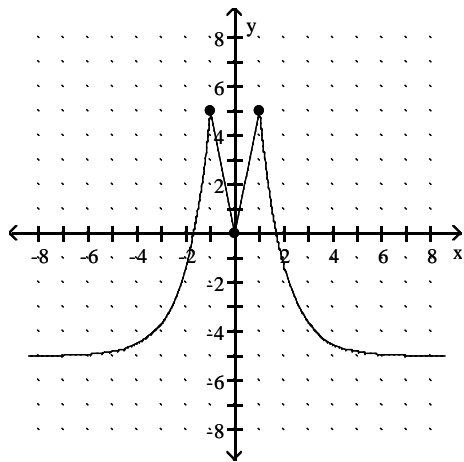

324) $f(0) = 4$, $f(1) = -4$, $f(-1) = -4$, $\lim_{x \rightarrow \pm\infty} f(x) = 0$.

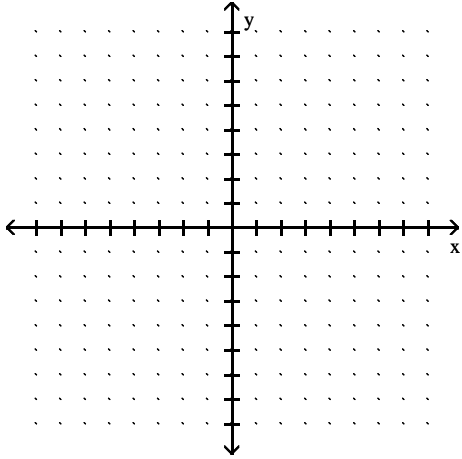

Answer: Answers may vary. One possible answer:

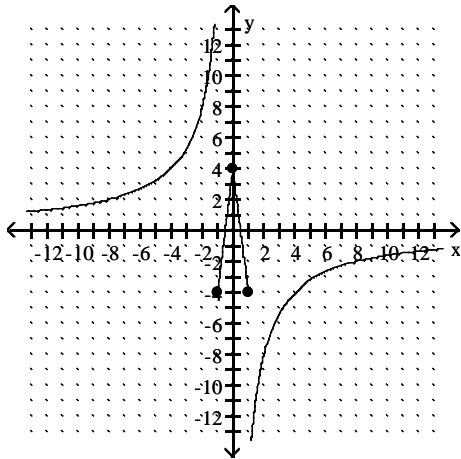

325) $f(0) = 0$, $\lim_{x \rightarrow \pm\infty} f(x) = 0$, $\lim_{x \rightarrow 6^-} f(x) = -\infty$, $\lim_{x \rightarrow 6^+} f(x) = -\infty$, $\lim_{x \rightarrow 6^+} f(x) = \infty$, $\lim_{x \rightarrow 6^-} f(x) = \infty$.

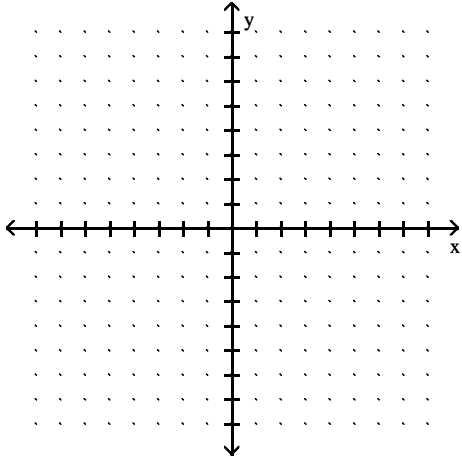

Answer: Answers may vary. One possible answer:

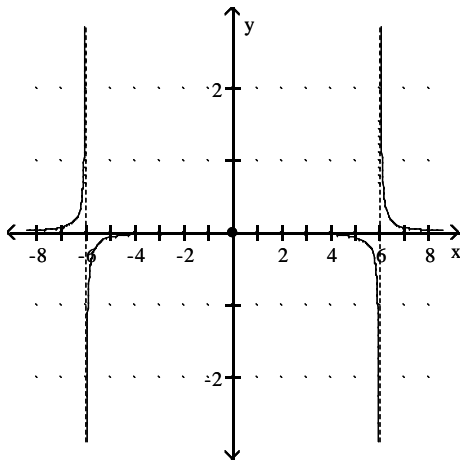

Find a function that satisfies the given conditions and sketch its graph.

$$326) \lim_{x \rightarrow \pm\infty} f(x) = 0, \quad \lim_{x \rightarrow 2^-} f(x) = \infty, \quad \lim_{x \rightarrow 2^+} f(x) = \infty.$$

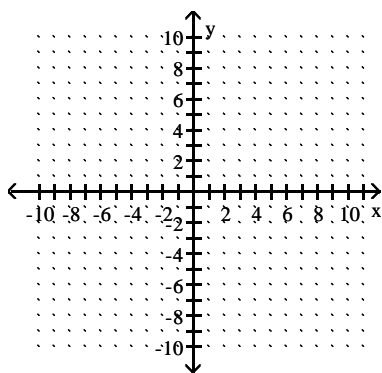

Answer: (Answers may vary.) Possible answer: $f(x) = \frac{1}{|x - 2|}$.

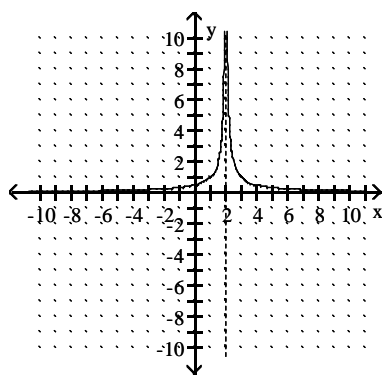

327) $\lim_{x \rightarrow \pm\infty} f(x) = 0$, $\lim_{x \rightarrow -5^-} f(x) = \infty$, $\lim_{x \rightarrow -5^+} f(x) = \infty$.

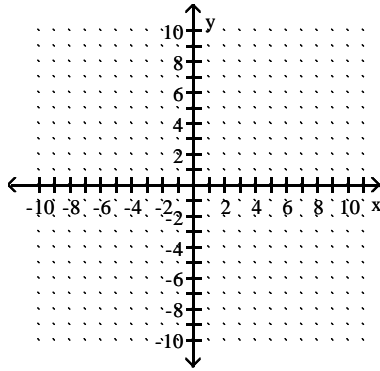

Answer: (Answers may vary.) Possible answer: $f(x) = \frac{1}{|x + 5|}$.

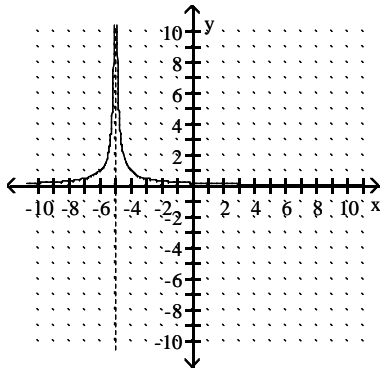

328) $\lim_{x \rightarrow -\infty} g(x) = -5$, $\lim_{x \rightarrow \infty} g(x) = 5$, $\lim_{x \rightarrow 0^+} g(x) = 5$, $\lim_{x \rightarrow 0^-} g(x) = -5$.

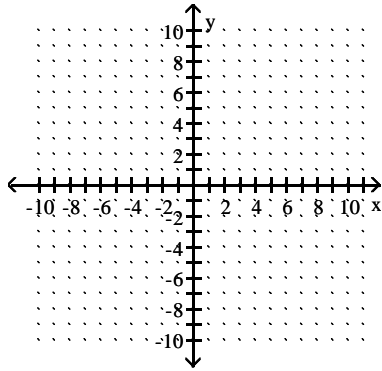

Answer: (Answers may vary.) Possible answer: $f(x) = \begin{cases} 5, & x > 0 \\ -5, & x < 0 \end{cases}$

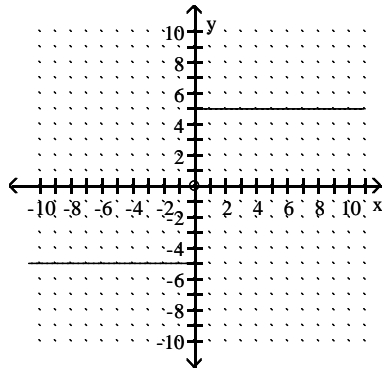

329) $\lim_{x \rightarrow \infty} f(x) = 0$, $\lim_{x \rightarrow 0^+} f(x) = \infty$.

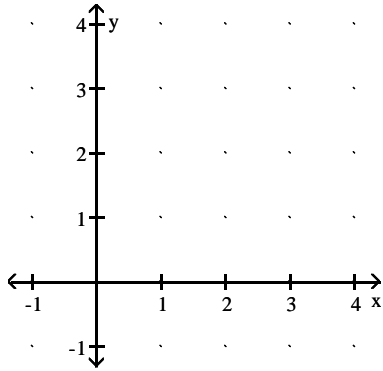

Answer: (Answers may vary.) Possible answer: $f(x) = \frac{1}{\sqrt{x}}$.

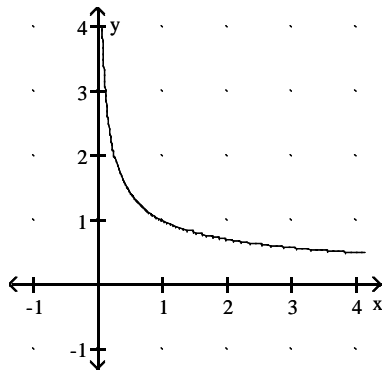

334) $\lim_{x \rightarrow \infty} \sqrt{x^2 + 2x} - \sqrt{x^2 - 8x}$

A) does not exist

B) 5

C) 10

D) - 3

Answer: B

Provide an appropriate response.

335) Which of the following statements defines $\lim_{x \rightarrow x_0} f(x) = \infty$?

I. For every positive real number B there exists a corresponding $\delta > 0$ such that $f(x) > B$ whenever $x_0 - \delta < x < x_0 + \delta$.

II. For every positive real number B there exists a corresponding $\delta > 0$ such that $f(x) > B$ whenever $x_0 < x < x_0 + \delta$.

III. For every positive real number B there exists a corresponding $\delta > 0$ such that $f(x) > B$ whenever $x_0 - \delta < x < x_0$.

A) III

B) II

C) I

D) None

Answer: C

336) Which of the following statements defines $\lim_{x \rightarrow (x_0)^-} f(x) = \infty$?

I. For every positive real number B there exists a corresponding $\delta > 0$ such that $f(x) > B$ whenever $x_0 - \delta < x < x_0 + \delta$.

II. For every positive real number B there exists a corresponding $\delta > 0$ such that $f(x) > B$ whenever $x_0 < x < x_0 + \delta$.

III. For every positive real number B there exists a corresponding $\delta > 0$ such that $f(x) > B$ whenever $x_0 - \delta < x < x_0$.

A) I

B) II

C) III

D) None

Answer: C

337) Which of the following statements defines $\lim_{x \rightarrow (x_0)^+} f(x) = \infty$?

I. For every positive real number B there exists a corresponding $\delta > 0$ such that $f(x) > B$ whenever $x_0 - \delta < x < x_0 + \delta$.

II. For every positive real number B there exists a corresponding $\delta > 0$ such that $f(x) > B$ whenever $x_0 < x < x_0 + \delta$.

III. For every positive real number B there exists a corresponding $\delta > 0$ such that $f(x) > B$ whenever $x_0 - \delta < x < x_0$.

A) III

B) I

C) II

D) None

Answer: C

338) Which of the following statements defines $\lim_{x \rightarrow x_0} f(x) = -\infty$?

- I. For every negative real number B there exists a corresponding $\delta > 0$ such that $f(x) < B$ whenever $x_0 - \delta < x < x_0 + \delta$.
- II. For every negative real number B there exists a corresponding $\delta > 0$ such that $f(x) < B$ whenever $x_0 < x < x_0 + \delta$.
- III. For every negative real number B there exists a corresponding $\delta > 0$ such that $f(x) < B$ whenever $x_0 - \delta < x < x_0$.

A) III B) I C) II D) None

Answer: B

339) Which of the following statements defines $\lim_{x \rightarrow (x_0)^+} f(x) = -\infty$?

- I. For every negative real number B there exists a corresponding $\delta > 0$ such that $f(x) < B$ whenever $x_0 - \delta < x < x_0 + \delta$.
- II. For every negative real number B there exists a corresponding $\delta > 0$ such that $f(x) < B$ whenever $x_0 < x < x_0 + \delta$.
- III. For every negative real number B there exists a corresponding $\delta > 0$ such that $f(x) < B$ whenever $x_0 - \delta < x < x_0$.

A) I B) III C) II D) None

Answer: C

340) Which of the following statements defines $\lim_{x \rightarrow (x_0)^-} f(x) = -\infty$?

- I. For every negative real number B there exists a corresponding $\delta > 0$ such that $f(x) < B$ whenever $x_0 - \delta < x < x_0 + \delta$.
- II. For every negative real number B there exists a corresponding $\delta > 0$ such that $f(x) < B$ whenever $x_0 < x < x_0 + \delta$.
- III. For every negative real number B there exists a corresponding $\delta > 0$ such that $f(x) < B$ whenever $x_0 - \delta < x < x_0$.

A) I B) III C) II D) None

Answer: B

341) Which of the following statements defines $\lim_{x \rightarrow -\infty} f(x) = \infty$?

- I. For every positive real number B there exists a corresponding positive real number N such that $f(x) > B$ whenever $x > N$.
- II. For every positive real number B there exists a corresponding negative real number N such that $f(x) > B$ whenever $x < N$.
- III. For every negative real number B there exists a corresponding negative real number N such that $f(x) < B$ whenever $x < N$.
- IV. For every negative real number B there exists a corresponding positive real number N such that $f(x) < B$ whenever $x > N$.

A) III B) IV C) I D) II

Answer: D

SHORT ANSWER. Write the word or phrase that best completes each statement or answers the question.

342) Use the formal definitions of limits to prove $\lim_{x \rightarrow 0} \frac{3}{|x|} = \infty$

Answer: Given $B > 0$, we want to find $\delta > 0$ such that $0 < |x - 0| < \delta$ implies $\frac{3}{|x|} > B$.

Now, $\frac{3}{|x|} > B$ if and only if $|x| < \frac{3}{B}$.

Thus, choosing $\delta = 3/B$ (or any smaller positive number), we see that

$|x| < \delta$ implies $\frac{3}{|x|} > \frac{3}{|\delta|} \geq B$.

Therefore, by definition $\lim_{x \rightarrow 0} \frac{3}{|x|} = \infty$

343) Use the formal definitions of limits to prove $\lim_{x \rightarrow 0^+} \frac{6}{x} = \infty$

Answer: Given $B > 0$, we want to find $\delta > 0$ such that $x_0 < x < x_0 + \delta$ implies $\frac{6}{x} > B$.

Now, $\frac{6}{x} > B$ if and only if $x < \frac{6}{B}$.

We know $x_0 = 0$. Thus, choosing $\delta = 6/B$ (or any smaller positive number), we see that

$x < \delta$ implies $\frac{6}{x} > \frac{6}{\delta} \geq B$.

Therefore, by definition $\lim_{x \rightarrow 0^+} \frac{6}{x} = \infty$

Answer Key

Testname: UNTITLED2

- 1) D
- 2) A
- 3) B
- 4) C
- 5) C
- 6) D
- 7) A
- 8) D
- 9) D
- 10) C
- 11) A
- 12) C
- 13) C
- 14) D
- 15) D
- 16) B
- 17) C
- 18) A
- 19) D
- 20) B
- 21) C
- 22) D
- 23) D
- 24) C
- 25) D
- 26) D
- 27) A
- 28) D
- 29) C
- 30) C
- 31) A
- 32) C
- 33) B
- 34) C
- 35) D
- 36) D
- 37) B
- 38) A
- 39) D
- 40) B
- 41) C
- 42) D
- 43) D
- 44) D
- 45) A
- 46) D
- 47) A
- 48) B
- 49) C
- 50) B

Answer Key

Testname: UNTITLED2

- 51) C
- 52) D
- 53) B
- 54) C
- 55) B
- 56) B
- 57) B
- 58) B
- 59) D
- 60) B
- 61) B
- 62) C
- 63) D
- 64) D
- 65) A
- 66) A
- 67) A
- 68) D
- 69) B
- 70) A
- 71) C
- 72) C
- 73) A
- 74) C
- 75) C
- 76) B
- 77) B
- 78) D
- 79) A
- 80) D
- 81) B
- 82) A
- 83) D
- 84) C
- 85) A
- 86) C
- 87) C
- 88) C
- 89) D
- 90) D
- 91) B
- 92) B
- 93) A
- 94) A
- 95) B
- 96) D
- 97) B
- 98) D
- 99) C
- 100) C

Answer Key

Testname: UNTITLED2

- 101) A
- 102) B
- 103) D
- 104) A
- 105) A
- 106) C
- 107) B
- 108) B
- 109) A
- 110) A
- 111) A
- 112) B
- 113) A
- 114) B
- 115) D
- 116) D
- 117) C
- 118) C
- 119) A
- 120) B

121) Answers may vary. One possibility: $\lim_{x \rightarrow 0} 1 - \frac{x^2}{6} = \lim_{x \rightarrow 0} 1 = 1$. According to the squeeze theorem, the function

$\frac{x \sin(x)}{2 - 2 \cos(x)}$, which is squeezed between $1 - \frac{x^2}{6}$ and 1, must also approach 1 as x approaches 0. Thus,

$$\lim_{x \rightarrow 0} \frac{x \sin(x)}{2 - 2 \cos(x)} = 1.$$

- 122) C
- 123) D
- 124) D
- 125) D
- 126) C
- 127) C
- 128) B
- 129) D
- 130) C
- 131) B
- 132) D
- 133) C
- 134) A
- 135) C
- 136) A
- 137) C
- 138) B
- 139) C
- 140) D
- 141) B
- 142) B
- 143) B

Answer Key

Testname: UNTITLED2

144) D

145) D

146) B

147) B

148) B

149) C

150) B

151) C

152) C

153)

Let $\varepsilon > 0$ be given. Choose $\delta = \varepsilon/2$. Then $0 < |x - 1| < \delta$ implies that

$$\begin{aligned} |(2x - 5) + 3| &= |2x - 2| \\ &= |2(x - 1)| \\ &= 2|x - 1| < 2\delta = \varepsilon \end{aligned}$$

Thus, $0 < |x - 1| < \delta$ implies that $|(2x - 5) + 3| < \varepsilon$

154) Let $\varepsilon > 0$ be given. Choose $\delta = \varepsilon$. Then $0 < |x - 7| < \delta$ implies that

$$\begin{aligned} \left| \frac{x^2 - 49}{x - 7} - 14 \right| &= \left| \frac{(x - 7)(x + 7)}{x - 7} - 14 \right| \\ &= |(x + 7) - 14| \quad \text{for } x \neq 7 \\ &= |x - 7| < \delta = \varepsilon \end{aligned}$$

Thus, $0 < |x - 7| < \delta$ implies that $\left| \frac{x^2 - 49}{x - 7} - 14 \right| < \varepsilon$

155) Let $\varepsilon > 0$ be given. Choose $\delta = \varepsilon/5$. Then $0 < |x - 2| < \delta$ implies that

$$\begin{aligned} \left| \frac{5x^2 - 8x - 4}{x - 2} - 12 \right| &= \left| \frac{(x - 2)(5x + 2)}{x - 2} - 12 \right| \\ &= |(5x + 2) - 12| \quad \text{for } x \neq 2 \\ &= |5x - 10| \\ &= |5(x - 2)| \\ &= 5|x - 2| < 5\delta = \varepsilon \end{aligned}$$

Thus, $0 < |x - 2| < \delta$ implies that $\left| \frac{5x^2 - 8x - 4}{x - 2} - 12 \right| < \varepsilon$

156) Let $\varepsilon > 0$ be given. Choose $\delta = \min\{3/2, 9\varepsilon/2\}$. Then $0 < |x - 3| < \delta$ implies that

$$\begin{aligned} \left| \frac{1}{x} - \frac{1}{3} \right| &= \left| \frac{3 - x}{3x} \right| \\ &= \frac{1}{|x|} \cdot \frac{1}{3} \cdot |x - 3| \\ &< \frac{1}{3/2} \cdot \frac{1}{3} \cdot \frac{9\varepsilon}{2} = \varepsilon \end{aligned}$$

Thus, $0 < |x - 3| < \delta$ implies that $\left| \frac{1}{x} - \frac{1}{3} \right| < \varepsilon$

157) D

158) A

159) D

160) B

161) D

162) A

163) A

Answer Key

Testname: UNTITLED2

- 164) B
- 165) B
- 166) B
- 167) B
- 168) B
- 169) B
- 170) A
- 171) A
- 172) D
- 173) B
- 174) C
- 175) C
- 176) A
- 177) A
- 178) D
- 179) A
- 180) A
- 181) B
- 182) B
- 183) A
- 184) D
- 185) B
- 186) A
- 187) B
- 188) A
- 189) D
- 190) B
- 191) C
- 192) A
- 193) B
- 194) B
- 195) B
- 196) C
- 197) D
- 198) D
- 199) C
- 200) D
- 201) D
- 202) C
- 203) C
- 204) C
- 205) A
- 206) B
- 207) D
- 208) C
- 209) B
- 210) A
- 211) B
- 212) D
- 213) A

Answer Key

Testname: UNTITLED2

- 214) B
 215) B
 216) B
 217) A
 218) B
 219) A
 220) B
 221) B
 222) B
 223) B
 224) D
 225) B
 226) B
 227) D
 228) A
 229) A
 230) D
 231) C
 232) A
 233) C
 234) D
 235) C
 236) A
 237) C
 238) B
 239) A
 240) D
 241) D
 242) D
 243) D
 244) A
 245) B
 246) B
 247) D
 248) A
 249) C
 250) B
 251) B
 252) B
 253) B
 254) Let $f(x) = 3x^3 + 9x^2 - 3x + 5$ and let $y_0 = 0$. $f(-4) = -31$ and $f(-3) = 14$. Since f is continuous on $[-4, -3]$ and since $y_0 = 0$ is between $f(-4)$ and $f(-3)$, by the Intermediate Value Theorem, there exists a c in the interval $(-4, -3)$ with the property that $f(c) = 0$. Such a c is a solution to the equation $3x^3 + 9x^2 - 3x + 5 = 0$.
 255) Let $f(x) = 5x^4 - 5x^3 + 3x - 10$ and let $y_0 = 0$. $f(-2) = 104$ and $f(-1) = -3$. Since f is continuous on $[-2, -1]$ and since $y_0 = 0$ is between $f(-2)$ and $f(-1)$, by the Intermediate Value Theorem, there exists a c in the interval $(-2, -1)$ with the property that $f(c) = 0$. Such a c is a solution to the equation $5x^4 - 5x^3 + 3x - 10 = 0$.

Answer Key

Testname: UNTITLED2

256) Let $f(x) = x(x - 2)^2$ and let $y_0 = 2$. $f(1) = 1$ and $f(3) = 3$. Since f is continuous on $[1, 3]$ and since $y_0 = 2$ is between $f(1)$ and $f(3)$, by the Intermediate Value Theorem, there exists a c in the interval $(1, 3)$ with the property that $f(c) = 2$. Such a c is a solution to the equation $x(x - 2)^2 = 2$.

257) Let $f(x) = \frac{\sin x}{x}$ and let $y_0 = \frac{1}{7}$. $f\left(\frac{\pi}{2}\right) \approx 0.6366$ and $f(\pi) = 0$. Since f is continuous on $\left[\frac{\pi}{2}, \pi\right]$ and since $y_0 = \frac{1}{7}$ is between $f\left(\frac{\pi}{2}\right)$ and $f(\pi)$, by the Intermediate Value Theorem, there exists a c in the interval $\left[\frac{\pi}{2}, \pi\right]$, with the property that $f(c) = \frac{1}{7}$.

Such a c is a solution to the equation $7 \sin x = x$.

258) B

259) B

260) The Intermediate Value Theorem implies that there is at least one solution to $f(x) = 0$ on the interval $[-1, 1]$.

Possible graph:

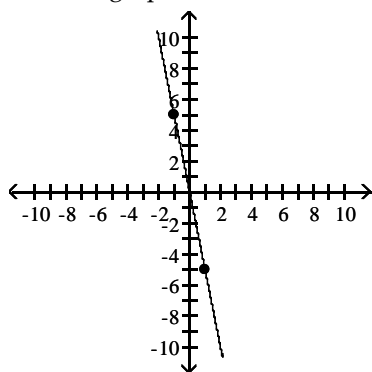

261) The roots of $f(x)$ are the solutions to the equation $f(x) = 0$. Statement (b) is asking for the solution to the equation $4x^3 = 3x + 4$. Statement (d) is asking for the solution to the equation $4x^3 - 3x = 4$. These three equations are equivalent to the equations in statements (c) and (e). As five equations are equivalent, their solutions are the same.

262) Notice that $f(0) = 5$ and $f(1) = 2$. As f is continuous on $[0, 1]$, the Intermediate Value Theorem implies that there is a number c such that $f(c) = \pi$.

263) Yes, if $f(x) = 1$ and $g(x) = x - 3$, then $h(x) = \frac{1}{x - 3}$ is discontinuous at $x = 3$.

264) Let $f(x) = \frac{\sin(x - 7)}{(x - 7)}$ be defined for all $x \neq 7$. The function f is continuous for all $x \neq 7$. The function is not defined at $x = 7$ because division by zero is undefined; hence f is not continuous at $x = 7$. This discontinuity is removable because $\lim_{x \rightarrow 7} \frac{\sin(x - 7)}{x - 7} = 1$. (We can extend the function to $x = 7$ by defining its value to be 1.)

265) Let $f(x) = \frac{1}{(x - 10)^2}$, for all $x \neq 10$. The function f is continuous for all $x \neq 10$, and $\lim_{x \rightarrow 10} \frac{1}{(x - 10)^2} = \infty$. As f is unbounded as x approaches 10, f is discontinuous at $x = 10$, and, moreover, this discontinuity is nonremovable.

266) D

267) A

268) A

269) A

270) A

271) B

272) D

273) A

Answer Key

Testname: UNTITLED2

- 274) D
- 275) D
- 276) A
- 277) C
- 278) B
- 279) C
- 280) B
- 281) A
- 282) A
- 283) D
- 284) D
- 285) C
- 286) D
- 287) D
- 288) D
- 289) C
- 290) D
- 291) A
- 292) A
- 293) D
- 294) C
- 295) A
- 296) A
- 297) C
- 298) A
- 299) A
- 300) C
- 301) A
- 302) D
- 303) B
- 304) D
- 305) B
- 306) A
- 307) B
- 308) D
- 309) C
- 310) D
- 311) D
- 312) C
- 313) A
- 314) A
- 315) D
- 316) C
- 317) A
- 318) D
- 319) D
- 320) D
- 321) A

Answer Key

Testname: UNTITLED2

322) Answers may vary. One possible answer:

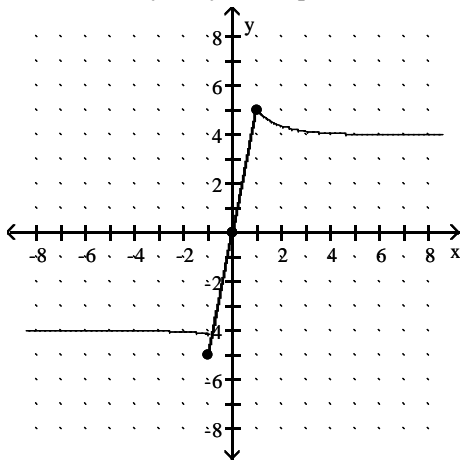

323) Answers may vary. One possible answer:

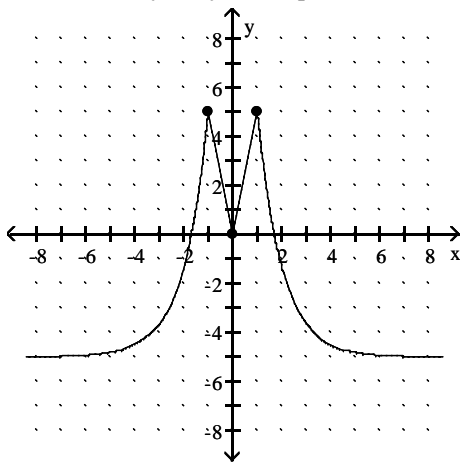

324) Answers may vary. One possible answer:

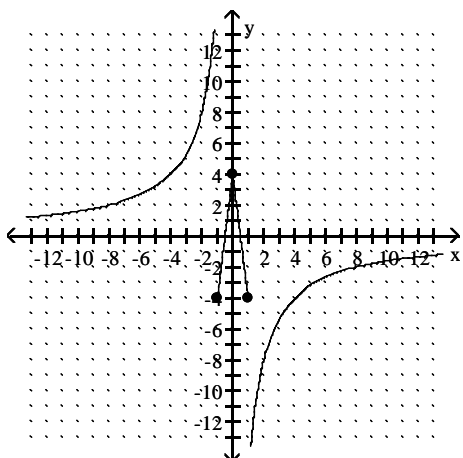

Answer Key

Testname: UNTITLED2

325) Answers may vary. One possible answer:

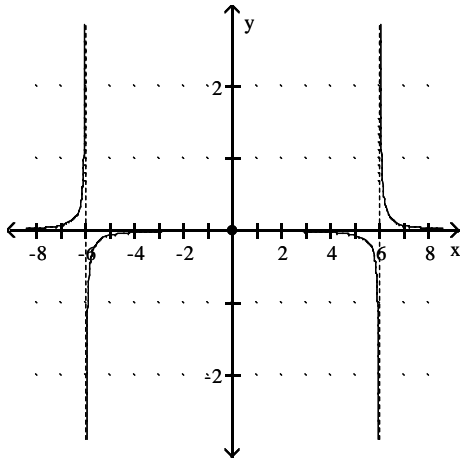

326) (Answers may vary.) Possible answer: $f(x) = \frac{1}{|x - 2|}$.

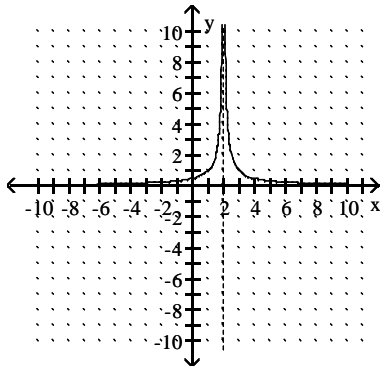

327) (Answers may vary.) Possible answer: $f(x) = \frac{1}{|x + 5|}$.

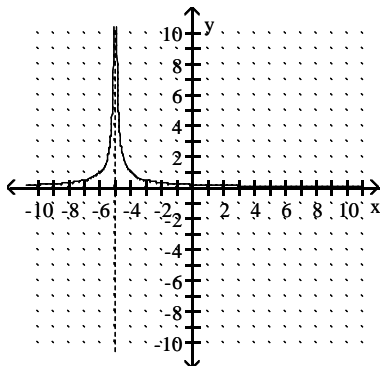

Answer Key

Testname: UNTITLED2

328) (Answers may vary.) Possible answer: $f(x) = \begin{cases} 5, & x > 0 \\ -5, & x < 0 \end{cases}$

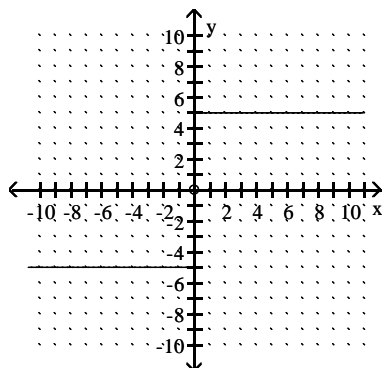

329) (Answers may vary.) Possible answer: $f(x) = \frac{1}{\sqrt{x}}$.

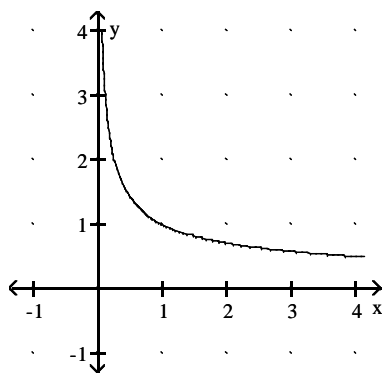

330) (Answers may vary.) Possible answer: $f(x) = \begin{cases} 1, & x < 0 \\ -1, & x > 0 \end{cases}$

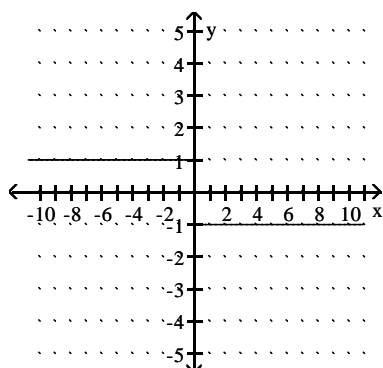

- 331) B
- 332) D
- 333) B
- 334) B
- 335) C
- 336) C
- 337) C
- 338) B
- 339) C
- 340) B
- 341) D

Answer Key

Testname: UNTITLED2

342) Given $B > 0$, we want to find $\delta > 0$ such that $0 < |x - 0| < \delta$ implies $\frac{3}{|x|} > B$.

Now, $\frac{3}{|x|} > B$ if and only if $|x| < \frac{3}{B}$.

Thus, choosing $\delta = 3/B$ (or any smaller positive number), we see that

$|x| < \delta$ implies $\frac{3}{|x|} > \frac{3}{|\delta|} \geq B$.

Therefore, by definition $\lim_{x \rightarrow 0} \frac{3}{|x|} = \infty$

343) Given $B > 0$, we want to find $\delta > 0$ such that $x_0 < x < x_0 + \delta$ implies $\frac{6}{x} > B$.

Now, $\frac{6}{x} > B$ if and only if $x < \frac{6}{B}$.

We know $x_0 = 0$. Thus, choosing $\delta = 6/B$ (or any smaller positive number), we see that

$x < \delta$ implies $\frac{6}{x} > \frac{6}{\delta} \geq B$.

Therefore, by definition $\lim_{x \rightarrow 0^+} \frac{6}{x} = \infty$